

DVMB-554E

**Socket 479 Intel Core™ 2 Duo/Core™
Duo/Core™ Solo Processor-based
533/667 MHz FSB Mini-ITX Motherboard
with PCI-E/DDR2/Dual GbE LAN/Video
Capture**

User Manual

Copyright

This document is copyrighted, 2006, by Advantech Co., Ltd. All rights are reserved. Advantech Co., Ltd. reserves the right to make improvements to the products described in this manual at any time without notice. No part of this manual may be reproduced, copied, translated or transmitted in any form or by any means without the prior written permission of Advantech Co., Ltd. Information provided in this manual is intended to be accurate and reliable. However, Advantech Co., Ltd. assumes no responsibility for its use, nor for any infringements upon the rights of third parties which may result from its use.

Acknowledgements

- AWARD is a trademark of Phoenix Technologies Ltd.
- IBM and PC are trademarks of International Business Machines Corporation.
- Intel®, Core™ 2 Duo/Core™ Duo/Core™ Solo are trademarks of Intel Corporation.
- WinBond is a trademark of Winbond Corporation.
- All other product names or trademarks are the properties of their respective owners.

A Message to the Customer

Advantech Customer Services

Each and every Advantech product is built to the most exacting specifications to ensure reliable performance in the harsh and demanding conditions typical of industrial environments. Whether your new Advantech equipment is destined for the laboratory or the factory floor, you can be assured that your product will provide the reliability and ease of operation for which the name Advantech has come to be known.

Your satisfaction is our primary concern. Here is a guide to Advantech's customer services. To ensure you get the full benefit of our services, please follow the instructions below carefully.

Technical Support

We want you to get the maximum performance from your products. So if you run into technical difficulties, we are here to help. For the most frequently asked questions, you can easily find answers in your product documentation. These answers are normally a lot more detailed than the ones we can give over the phone.

So please consult this manual first. If you still cannot find the answer, gather all the information or questions that apply to your problem, and with the product close at hand, call your dealer. Our dealers are well trained and ready to give you the support you need to get the most from your Advantech products. In fact, most problems reported are minor and are able to be easily solved over the phone.

In addition, free technical support is available from Advantech engineers every business day. We are always ready to give advice on application requirements or specific information on the installation and operation of any of our products.

Certifications

FCC

This device complies with the requirements in part 15 of the FCC rules: Operation is subject to the following two conditions:

- This device may not cause harmful interference
- This device must accept any interference received, including interference that may cause undesired operation

This equipment has been tested and found to comply with the limits for a Class A digital device, pursuant to Part 15 of the FCC Rules. These limits are designed to provide reasonable protection against harmful interference when the equipment is operated in a commercial environment. This equipment generates, uses, and can radiate radio frequency energy and, if not installed and used in accordance with the instruction manual, may cause harmful interference to radio communications. Operation of this device in a residential area is likely to cause harmful interference in which case the user will be required to correct the interference at his/her own expense. The user is advised that any equipment changes or modifications not expressly approved by the party responsible for compliance would void the compliance to FCC regulations and therefore, the user's authority to operate the equipment.

Caution! *There is a danger of a new battery exploding if it is incorrectly installed. Do not attempt to recharge, force open, or heat the battery. Replace the battery only with the same or equivalent type recommended by the manufacturer. Discard used batteries according to the manufacturer's instructions.*

Product warranty

Advantech warrants to you, the original purchaser, that each of its products will be free from defects in materials and workmanship for two years from the date of purchase.

This warranty does not apply to any products which have been repaired or altered by persons other than repair personnel authorized by Advantech, or which have been subject to misuse, abuse, accident or improper installation. Advantech assumes no liability under the terms of this warranty as a consequence of such events.

If an Advantech product is defective, it will be repaired or replaced at no charge during the warranty period. For out-of-warranty repairs, you will be billed according to the cost of replacement materials, service time and freight. Please consult your dealer for more details.

If you think you have a defective product, follow these steps:

1. Collect all the information about the problem encountered. (For example, type of PC, CPU speed, Advantech products used, other hardware and software used, etc.) Note anything abnormal and list any on-screen messages you get when the problem occurs.
2. Call your dealer and describe the problem. Please have your manual, product, and any helpful information readily available.
3. If your product is diagnosed as defective, obtain an RMA (return material authorization) number from your dealer. This allows us to process your return more quickly.
4. Carefully pack the defective product, a fully-completed Repair and Replacement Order Card and a photocopy proof of purchase date (such as your sales receipt) in a shippable container. A product returned without proof of the purchase date is not eligible for warranty service.
5. Write the RMA number visibly on the outside of the package and ship it prepaid to your dealer.

Initial Inspection

Before you begin installing your motherboard, please make sure that the following materials have been shipped:

- DVMB-554E Socket 479 Intel Core™ 2 Duo/Core™ Duo/Core™ Solo Processor-based Industrial Mini-ITX Motherboard P/N: 9692055000E
- 1 DVA-210 4*Channels BNC Connector Module with bracket P/N: 9692A21000E
- 1 CD with driver utility and manual P/N: 2066554E00
- 1 flat cable for DVA-210 P/N: 1700000860
- 2 Serial ATA HDD data cable P/N: 1700002155
- 1 Parallel ATA HDD power cable IDE44/40/40P 63cm P/N: 1701440630
- 1 Parallel ATA HDD power cable IDE44/44P 15cm P/N: 1701440159
- 1 ATX 12V power converter cable P/N: 1700003411
- 1 CPU Heat Sink P/N: 1960004032
- 1 PS/2 Y cable for KB&MS P/N: 1700060202
- 2 warranty card P/N: 2190000902

If any of these items are missing or damaged, contact your distributor or sales representative immediately. We have carefully inspected the DVMB-554E mechanically and electrically before shipment. It should be free of marks and scratches and in perfect working order upon receipt. As you unpack the DVMB-554E, check it for signs of shipping damage. (For example, damaged box, scratches, dents, etc.) If it is damaged or it fails to meet the specifications, notify our service department or your local sales representative immediately. Also notify the carrier. Retain the shipping carton and packing material for inspection by the carrier. After inspection, we will make arrangements to repair or replace the unit.

Table of Contents

Chapter 1 Hardware Configuration.....	13
1.1 Introduction	13
1.2 Features	14
1.3 Specifications	14
1.3.1 System	14
1.3.2 Memory	15
1.3.3 Input/Output	15
1.3.4 Graphics	15
1.3.5 Ethernet LAN	16
1.3.6 Industrial features	16
1.3.7 Mechanical and environmental specifications.....	16
1.4 Jumpers and Connectors.....	17
1.5 Board Layout: Jumper and Connector Locations	19
1.6 DVMB-554E Block Diagram.....	20
1.7 Safety Precautions	21
1.8 Jumper Settings.....	22
1.8.1 How to set jumpers	22
1.8.2 CMOS clear (J3).....	22
1.8.3 Watchdog timer output (J4)	23
1.8.4 COM2 RS 232/422/485 mode selector (J2)	24
1.8.5 LVDS Power 3.3V/5V selector (J6)	24
1.9 System Memory	25
1.9.1 CPU FSB and memory speed	25
1.10 Memory Installation Procedures.....	25
1.11 Cache Memory	25
1.12 Processor Installation	26
Chapter 2 Connecting Peripherals.....	28
2.1 Introduction	28
2.2 Primary IDE Connector (CN11).....	28
2.3 USB Ports and LAN Ports (CN4, CN5, CN9, CN10).....	29
2.4 VGA and DVI connector module (V1).....	30
2.5 Serial port module: COM1/COM2 (CM1)	30
2.6 External PS/2 and Composite TV-Out (CN2)	31
2.7 Fan Connector (FN1/FN2/FN3)	31

2.8	Front Panel Connectors (CNX1/CN13).....	32
2.8.1	Power LED and Keyboard Lock (CN13).....	32
2.8.2	External Speaker (CNX1-17).....	32
2.8.3	Reset Connector (CNX1-18)	33
2.8.4	HDD LED Connector (CNX1-19).....	33
2.8.5	ATX Soft Power Switch (CNX1-21)	33
2.8.6	SM Bus Connector (CNX1-29)	33
2.9	H/W Monitor Alarm (CN12).....	34
2.10	Line Out, Mic In Connector (CN3)	34
2.11	Aux Line-In Connector (CN7).....	35
2.12	Serial ATA Interface (SA1, SA2)	35
2.13	DVA-210 Connector (VDO1).....	36
2.14	Auxiliary 4-pin power connector (ATX1).....	36
2.15	GPIO connector (GPIO1).....	37
2.16	LVDS connector (VCN1)	38
2.17	LCD Inverter Power connector (BKL1).....	39
Chapter 3	Award BIOS Setup.....	41
3.1	Introduction	41
3.1.1	CMOS RAM Auto-backup and Restore.....	41
3.2	Entering Setup.....	42
3.3	Standard CMOS Setup	42
3.3.1	Date	42
3.3.2	Time	42
3.3.3	IDE channel 0/1 Master/Slave	42
3.3.4	Halt On.....	43
3.3.5	Memory	43
3.4	Advanced BIOS Features	44
3.4.1	CPU Features.....	45
3.4.2	Hard Disk Boot Priority.....	45
3.4.3	Virus Warning	45
3.4.4	CPU L1, L2 & L3 Cache	45
3.4.5	Quick Power On Self Test	45
3.4.6	First/Second Boot Device	45
3.4.7	Boot Other Device.....	45
3.4.8	Boot Up NumLock Status.....	46
3.4.9	Gate A20 Option.....	46

3.4.10 Typematic Rate Setting	46
3.4.11 Typematic Rate (Chars/Sec)	46
3.4.12 Typematic Delay (msec)	46
3.4.13 Security Option	46
3.4.14 APIC Mode	46
3.4.15 MPS Version Control For OS	47
3.5 Advanced Chipset Features	47
3.5.1 DRAM Timing Selectable	48
3.5.2 CAS Latency Time	48
3.5.3 DRAM RAS# to CAS# Delay	48
3.5.4 DRAM RAS# Precharge	49
3.5.5 Precharge Delay (t RAS)	49
3.5.6 System Memory Frequency	49
3.5.7 System BIOS Cacheable.....	49
3.5.8 Video BIOS Cacheable.....	49
3.5.9 Memory Hole At 15M-16M	49
3.5.10 PCI-Express Root Port Func.....	49
3.5.11 PEG / Onchip VGA Control	50
3.5.12 On-Chip Frame Buffer Size.....	50
3.5.13 DVMT Mode.....	50
3.5.14 DVMT / FIXED Memory Size	50
3.5.15 Boot Display.....	50
3.5.16 Panel Number	50
3.5.17 Init Display First.....	51
3.6 Integrated Peripherals.....	51
3.6.1 IDE HDD Block Mode	52
3.6.2 IDE DMA Transfer Access.....	52
3.6.3 On-Chip Primary / Secondary IDE Device	52
3.6.4 SATA Mode.....	52
3.6.5 On-Chip Serial ATA	53
3.6.6 PATA IDE Mode	53
3.6.7 SATA Port	53
3.6.8 USB Controller.....	53
3.6.9 USB 2.0 Controller.....	54
3.6.10 USB Keyboard / Mouse Support	54
3.6.11 AC97 Audio.....	54

3.6.12	Onboard LAN1 Control	54
3.6.13	Onboard LAN2 Control	54
3.6.14	Capture Controller	54
3.6.15	Onboard Serial Port 1	54
3.6.16	Onboard Serial Port 2	54
3.6.17	UART Mode Select	55
3.6.18	RxD, TxD Active.....	55
3.6.19	IR Transmission Delay	55
3.6.20	UR2 Duplex Mode	55
3.6.21	Use IR Pins.....	55
3.6.22	Watch Dog Timer Select	55
3.7	Power Management Setup.....	56
3.7.1	PCI Express PM Function	57
3.7.2	ACPI Function.....	57
3.7.3	Power Management	57
3.7.4	Video Off Method	57
3.7.5	Video Off In Suspend	57
3.7.6	Suspend Type	58
3.7.7	Modem Use IRQ.....	58
3.7.8	Suspend Mode	58
3.7.9	HDD Power Down	58
3.7.10	Soft-Off by PWR-BTTN.....	58
3.7.11	PowerOn by LAN.....	58
3.7.12	CPU THRM-Throttling.....	58
3.7.13	PowerOn by Modem.....	58
3.7.14	PowerOn by Alarm.....	58
3.7.15	Primary IDE 0 (1) and Secondary IDE 0 (1).....	58
3.7.16	FDD, COM, LPT PORT	59
3.7.17	PCI PIRQ [A-D]#.....	59
3.7.18	PWRON After PWR-Fail	59
3.8	PnP/PCI Configurations	60
3.8.1	Reset Configuration Data.....	60
3.8.2	Resources Controlled By	60
3.8.3	PCI / VGA Palette Snoop	60
3.8.4	Maximum Payload Size	60
3.9	PC Health Status.....	61

3.9.1 CPU Warning Temperature.....	61
3.9.2 Current System Temperature	61
3.9.3 Current CPU Temperature	61
3.9.4 CPU FAN Speed.....	61
3.9.5 System FAN 1 / 2 Speed.....	61
3.9.6 VCORE and Other Voltages	61
3.9.7 Shutdown Temperature.....	61
3.10 Frequency / Voltage Control	62
3.10.1 Spread Spectrum.....	62
3.11 Password Setting.....	63
3.12 Save & Exit Setup	63
3.13 Exit Without Saving	63
Chapter 4 Chipset Installation	65
4.1 Before you begin.....	65
4.2 Introduction	65
4.3 Windows XP Driver Setup	66
Chapter 5 VGA Setup	70
5.1 Introduction.....	70
5.2 Windows XP Driver Setup	70
Chapter 6 Video capture installation	74
6.1 Driver installation of video capture chip	74
6.2 Installation of DVMB-554E Demo Program.....	82
6.3 Demo Program Functionality	86
6.3.1 Device.....	86
6.3.2 Switch Channels	87
6.3.3 Resolution.....	88
6.3.4 Frame Rate.....	89
6.3.5 Video Mux.....	90
6.3.6 Video Standard	91
6.3.7 Snap Buffer.....	92
6.3.8 Sensor Control	93
6.3.9 Micro Control	94
6.3.10 GPIO control	94

1

General Information

Chapter 1 Hardware Configuration

1.1 Introduction

The DVMB-554E is designed with the Intel® 945GM and the ICH7M-DH for industrial applications that require both high-performance computing and enhanced power management capabilities. The motherboard supports Intel Core™ 2 Duo/Core™ Duo/Core™ Solo Processor up to 2.16GHz with 533/667 MHz front side bus and Dual Channel DDRII 533/667 MHz memory up to 4 GB.

The DVMB-554E offers high-performance cost-saving integrated graphics, built on the Intel® 945GM chipset and features the unique Intel® Extreme Graphics architecture that maximizes VGA performance and shares system memory up to 224MB. Better still, the DVMB-554E also provides incredible visual quality, versatile display options, 8-bit Dual Channel LVDS and a TV-out(NTSC/PAL) interface.

In addition to powerful computing capabilities, the DVMB-554E comes with advanced I/O enhancements. The DVMB-554E possess multiple high performance onboard I/O capabilities which include one PCI-Express x4 slot; one Mini-PCI socket; eight high-speed USB 2.0 ports; two Serial ATA ports supporting up to two devices with software Serial ATA RAID 0,1; AC-97 audio; two RS-232 ports; one parallel ATA port. These powerful I/O capabilities ensure even more reliable data storage capabilities and suitable for work with high-speed I/O peripherals.

With all these exceptional features and outstanding performance, DVMB-554 is simply the best, most advanced yet power saving platform for today and tomorrow's up-and-coming applications.

1.2 Features

- **PCI&PCI Express architecture:** Designed with the Intel 945GM and ICH7M-DH PCI-Express chipset, the DVMB-554E has dual/single Giga-bit LAN via PCI-E x1 bus, 1 Mini-PCI socket and 1 PCI-E x 4 slot.
- **High Performance I/O Capability:** Mini-PCI and Dual Gigabit LAN via PCI-E x1 bus, 2 SATA connectors and 8 USB 2.0 ports.
- **Standard Mini-ITX form factor with industrial features:** DVMB-554E provides industrial features like long product life, reliable operation under wide temperature range, watchdog timer, CMOS backup functions, etc.
- **BIOS CMOS backup and restore:** When BIOS CMOS setup has been completed, data in the CMOS RAM is automatically backed up to the Flash ROM. This is particularly useful in harsh environments which may cause setup data loss such as battery failure. Upon such an error occurring, BIOS will check the data, and automatically restore the original data for booting.
- **Automatically power on after power failure:** It is often required to have an unattended system come back to operation when power resumes after a power failure. Advantech's industrial motherboard allows users to set the system to power on automatically without pushing the power on button.

1.3 Specifications

1.3.1 System

- **CPU:** Socket 479 Intel Core™ 2 Duo/Core™ Duo/Core™ Solo up to 2.16GHz 533/667 MHz FSB.
- **L2 Cache:** CPU has built-in 2MB or 4MB CPU full-speed L2 cache.
- **BIOS:** Award Flash BIOS (4Mb Flash Memory)
- **System Chipset:** Intel 945GM with ICH7M-DH
- **SATA/EIDE hard disk drive interface:** Two on-board SATA connectors with data transmission rate up to 150 MB/s, and supports up to two devices with software Serial ATA RAID 0,1. One on-board IDE connector supporting up to two enhanced IDE devices. Supports PIO mode 4 (16.67MB/s data transfer rate) and ATA 33/66/100 (33/66/100MB/s data transfer rate.) BIOS enabled/disabled.

1.3.2 Memory

- **RAM:** Up to 4 GB in four 240-pin DIMM sockets. Supports dual-channel DDRII 400/533/667 SDRAM.

1.3.3 Input/Output

- **PCI Express slots:** 1 PCI-E x 3 with PCI-E x 4 expansion slot (this expansion slot works with Advantech Riser card) and 1 PCI-E x 1 gold finger.
- **PCI Bus:** 1 Mini-PCI socket, 32-bit, 33 MHz PCI 2.2 compliant
- **Serial ports:** Two serial ports, one DB-9 (RS 232)connector and one on-board pin header (RS 232/422/485). Ports can be individually configured to COM1, COM2, or disabled
- **Keyboard and PS/2 mouse connector:** One 6-pin Mini-DIN connectors are located on the mounting bracket and work with special Y cable for easy connection to a PS/2 keyboard and mouse.
- **USB port:** Supports up to eight USB 2.0 ports with transmission rate up to 480Mbps.

1.3.4 Graphics

- **Controller:** Intel Graphics Media Accelerator 950
- **Display memory:** Dynamically shared system memory up to 224 MB.
- **VGA:** Up to 2048x1536 resolution@75Hz
- **LVDS interface:** Support up to UXGA(1600X1200)
- **TV-Out:** NTSC/PAL.

1.3.5 Ethernet LAN

- Supporting single/dual 10/100/1000Base-T Ethernet port(s) via PCI Express x1 bus which provides 500 MB/s data transmission rate.
- **Controller:**
Marvell 88E8053 PCI-E Gigabit LAN; featuring AI NET2

1.3.6 Industrial features

- **Watchdog timer:** Can generate a system reset or IRQ11. The watchdog timer is programmable, with each unit equal to one second or one minute (255 levels)

1.3.7 Mechanical and environmental specifications

- **Operating temperature:** 0 ~ 60° C (32 ~ 140° F, Depending on CPU)
- **Storage temperature:** -20 ~ 70° C (-4 ~ 158° F)
- **Humidity:** 20 ~ 95% non-condensing
- **Power supply voltage:** +3.3V, ±5 V, ±12 V
- **Power consumption:** Maximum: +5 V at 2.4A, +3.3V at 3A, +12V at 1.3A Intel Core Duo 2GHz (667 MHz FSB), 2 x 1GB DDR2 667 SDRAM)
- **Board size:** 170 x 170 mm (6.69" x 6.69")
- **Board weight:** 0.7 kg (1.68 lb)

1.4 Jumpers and Connectors

Connectors on the DVMB-554E motherboard link it to external devices such as hard disk drives and a keyboard. In addition, the board has a number of jumpers used to configure your system for your application.

The tables below list the function of each of the board jumpers and connectors. Later sections in this chapter give instructions on setting jumpers. Chapter 2 gives instructions for connecting external devices to your motherboard.

Label	Function
J2	COM2 RS232/422/485 selectors
J3	CMOS Clear
J4	Watchdog timer output selection
J5	AT/ATX mode selector
J6	LVDS Power 3.3V/5V selector

Label	Function
CM1	Serial port module: COM1/COM2
CN2	External PS/2 and Composite TV-Out
CN3	Line Out/MIC In connector
CN4	LAN2; USB ports 3, 4
CN5	LAN1; USB ports 1, 2
CN6	Rear Panel audio connector
CN7	AUX-IN connector
CN8	IrDA connector
CN9	USB ports 5, 6
CN10	USB ports 7, 8
CN11	Primary IDE connector
CN12	Hardware Monitor connector
CN13	Power LED

Label	Function
CNX1	Power/Reset/HDD LED/Alarm speaker connector
GPIO1	GPIO connector
VDO1	DVA-210 connector
FN1	FAN connector
FN2	FAN connector
FN3	FAN connector
SMBUS1	SMBus Extend connector
SA1	Serial ATA1
SA2	Serial ATA2
VCN1	LVDS connector
BKL1	LCD Inverter Power/Back light connector
V1	VGA and DVI connector module
ATX1	ATX 12 V auxiliary power connector
ATX2	20-pin ATX power connector

1.5 Board Layout: Jumper and Connector Locations

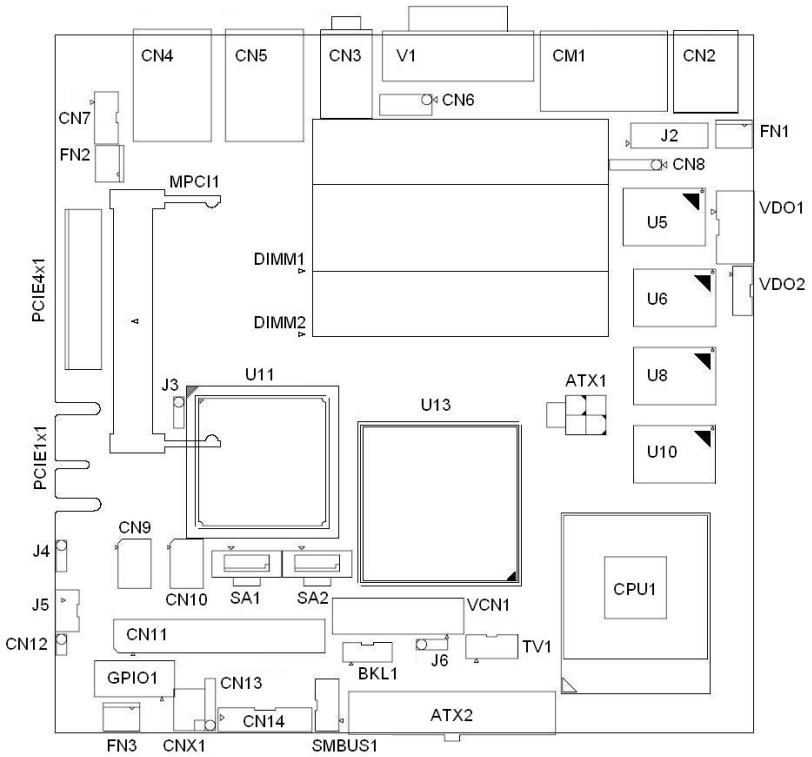

Figure 1.1: Jumper and Connector locations

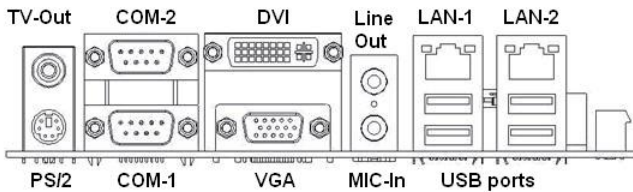

Figure 1.2: Rear Panel Placement

1.6 DVMB-554E Block Diagram

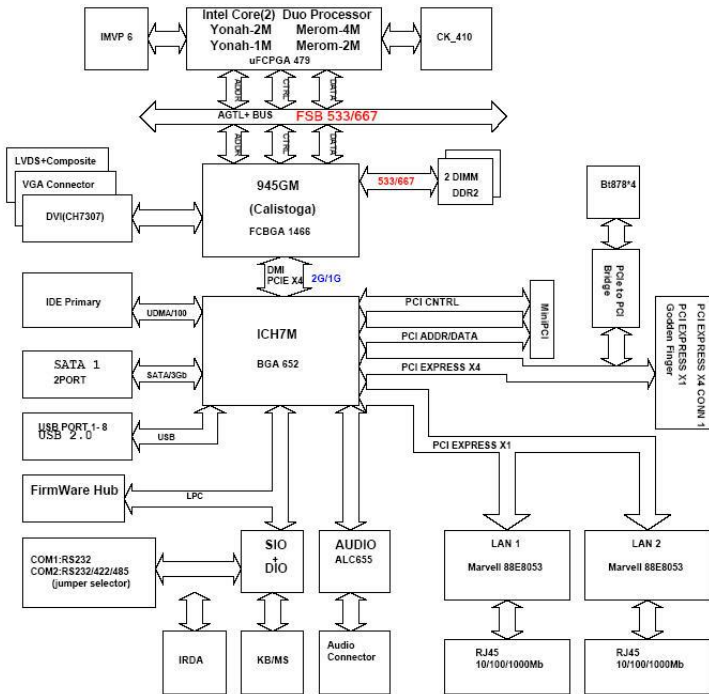

Figure 1.3: DVMB-554E Block Diagram

1.7 Safety Precautions

Warning! *Always completely disconnect the power cord from your chassis whenever you work with the hardware. Do not make connections while the power is on. Sensitive electronic components can be damaged by sudden power surges. Only experienced electronics personnel should open the PC chassis.*

Caution! *Always ground yourself to remove any static charge before touching the motherboard. Modern electronic devices are very sensitive to static electric charges. As a safety precaution, use a grounding wrist strap at all times. Place all electronic components on a static-dissipative surface or in a static-shielded bag when they are not in the chassis.*

Caution! *The computer is provided with a battery-powered Real-time Clock circuit. There is a danger of explosion if battery is incorrectly replaced. Replace only with same or equivalent type recommended by the manufacturer. Discard used batteries according to manufacturer's instructions.*

Caution! *There is a danger of a new battery exploding if it is incorrectly installed. Do not attempt to recharge, force open, or heat the battery. Replace the battery only with the same or equivalent type recommended by the manufacturer. Discard used batteries according to the manufacturer's instructions.*

1.8 Jumper Settings



This section provides instructions on how to configure your motherboard by setting the jumpers. It also includes the motherboards's default settings and your options for each jumper.

1.8.1 How to set jumpers

You can configure your motherboard to match the needs of your application by setting the jumpers. A jumper is a metal bridge that closes an electrical circuit. It consists of two metal pins and a small metal clip (often protected by a plastic cover) that slides over the pins to connect them. To “close” (or turn ON) a jumper, you connect the pins with the clip. To “open” (or turn OFF) a jumper, you remove the clip. Sometimes a jumper consists of a set of three pins, labeled 1, 2, and 3. In this case you connect either pins 1 and 2, or 2 and 3. A pair of needle-nose pliers may be useful when setting jumpers.

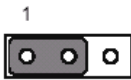

1.8.2 CMOS clear (J3)

The DVMB-554E motherboard contains a jumper that can erase CMOS data and reset the system BIOS information. Normally this jumper should be set with pins 1-2 closed. If you want to reset the CMOS data, set J1 to 2-3 closed for just a few seconds, and then move the jumper back to 1-2 closed. This procedure will reset the CMOS to its default setting.

Function	Jumper Setting
* Keep CMOS data	 1-2 closed
Clear CMOS data	 2-3 closed
* default setting	



1.8.3 Watchdog timer output (J4)

The DVMB-554E contains a watchdog timer that will reset the CPU or send a signal to PIRQE in the event the CPU stops processing. This feature means the DVMB-554E will recover from a software failure or an EMI problem. The J4 jumper settings control the outcome of what the computer will do in the event the watchdog timer is tripped.

Function	Jumper Setting
IRQ11	1  1-2 closed
* Reset	1  2-3 closed

*default setting

Note: The interrupt output of the watchdog timer is a low level signal. It will be held low until the watchdog timer is reset.

Function	Jumper Setting
AT Mode	1  1-2 closed
ATX Mode	1  2-3 closed

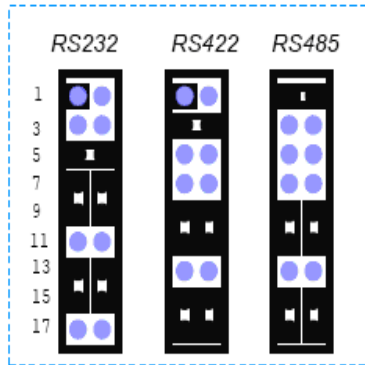

1.8.4 COM2 RS 232/422/485 mode selector (J2)

Users can use J2 to select among RS 232/422/485 modes for COM2. The default setting is RS 232.



Function	Jumper Setting
RS232	(5-6) + (7-9) + (8-10) + (13-15) + (14-16) closed
RS422	(3-4) + (9-11) + (10-12) + (15-17) + (16-18) closed
RS485	(1-2) + (9-11) + (10-12) + (15-17) + (16-18) closed

1.8.5 LVDS Power 3.3V/5V selector (J6)

Function	Jumper Setting
5V	 1-2 closed
*3.3V	 2-3 closed

*default setting

1.9 System Memory

The DVMB-554E has two sockets for 240-pin memory modules (SO-DIMMs). All these sockets use 1.8 V unbuffered double data rate synchronous DRAMs (DDR SDRAM). They are available in capacities of 256, 512 and 1024 MB. The sockets can be filled in any combination with DIMMs of any size, giving a total memory size between 256 MB and 2GB.

1.9.1 CPU FSB and memory speed

The DVMB-554E can accept DDR2 SDRAM memory chips without parity. Also note: The DVMB-554E accepts DDR2 400/533/667MHz SDRAM, and DDR2 SDRAM. The DVMB-554E does NOT support ECC (error checking and correction).

1.10 Memory Installation Procedures

To install DIMMs, first make sure the two handles of the DIMM socket are in the “open” position. i.e. The handles lean outward. Slowly slide the DIMM module along the plastic guides on both ends of the socket. Then press the DIMM module right down into the socket, until you hear a click. This is when the two handles have automatically locked the memory module into the correct position of the DIMM socket. To remove the memory module, just push both handles outward, and the memory module will be ejected by the mechanism in the socket.

1.11 Cache Memory

The CPU that DVMB-554E supports built-in 2MB or 4MB cache memory.

1.12 Processor Installation

Warning: Without a fan or heat sink, the CPU will over-heat and cause damage to both the CPU and the single board computer. To install a CPU, first turn off your system. Locate the processor socket 479.

The DVMB-554E is designed for Intel Core™ 2 Duo/Core™ Duo/Core™ Solo (socket 479) up to 2.16 GHz. Follow these steps to install the processor:

1. Turn the screw to loosen the processor socket.
2. Align the triangular marking on the processor with the small arrow on the corner of the socket.
3. Turn the screw to its original position.
4. Install the heat sink on the CPU. The concave of heat sink should face to location of capacitors to avoid contacting with capacitors.

2

Connecting Peripherals

Chapter 2 Connecting Peripherals

2.1 Introduction

You can access most of the connectors from the top of the board as it is being installed in the chassis. If you have a number of cards installed or have a packed chassis, you may need to partially remove the card to make all the connections.

2.2 Primary IDE Connector (CN11)

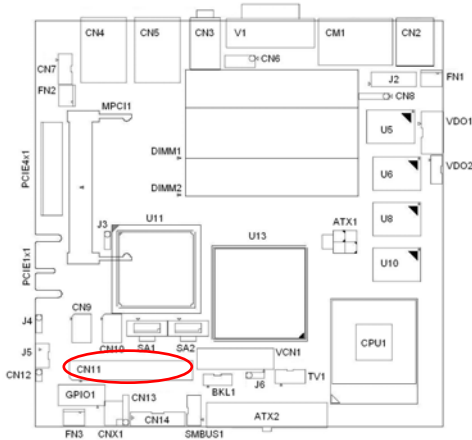

You can attach up to two IDE (Integrated Drive Electronics) drives to the DVMB-554E's built-in controller. The primary (CN11) connector can each accommodate two drives.

Wire number 1 on the cable is red or blue and the other wires are gray. Connect one end to connector CN11 on the motherboard. Make sure that the red/blue wire corresponds to pin 1 on the connector (in the upper right hand corner). See Chapter 1 for help finding the connector.

Unlike floppy drives, IDE hard drives can connect in either position on the cable. If you install two drives to a single connector, you will need to set one as the master and the other as the slave. You do this by setting the jumpers on the drives. If you use just one drive on the connector, you should set the drive as the master. See the documentation that came with your drive for more information.

Connect the first hard drive to the other end of the cable. Wire 1 on the

cable should also connect to pin 1 on the hard drive connector, which is labeled on the drive circuit board. Check the documentation that came with the drive for more information.

2.3 USB Ports and LAN Ports (CN4, CN5, CN9, CN10)

The DVMB-554E provides up to eight ports of USB (Universal Serial Bus) interface which gives complete Plug & Play and hot swapping for up to 127 external devices. The USB interface complies with USB Specification Rev. 2.0 supporting transmission rate up to 480 Mbps and is fuse protected. The USB interface can be disabled in the system BIOS setup.

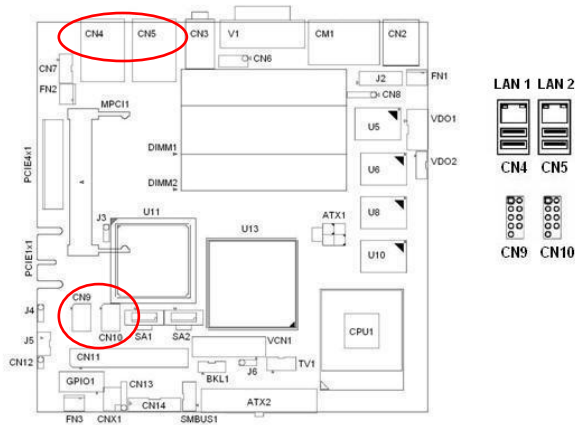

The DVMB-554E is equipped with one or two high-performance 1000 Mbps Ethernet LANs. They are supported by all major network operating systems. The RJ-45 jacks on the rear plate provide convenient or 1000 Base-T operation.

Lan mode	Lan Indicator
1Gbps Link on	LED1 Green on
100Mbps Link on	LED1 Orange on
Active	LED2 Green flash

2.4 VGA and DVI connector module (V1)

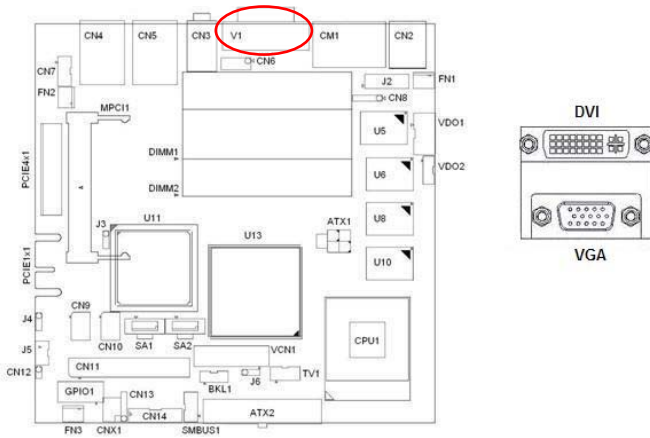

The DVMB-554E includes DVI and VGA interface that can drive dual displays.

2.5 Serial port module: COM1/COM2 (CM1)

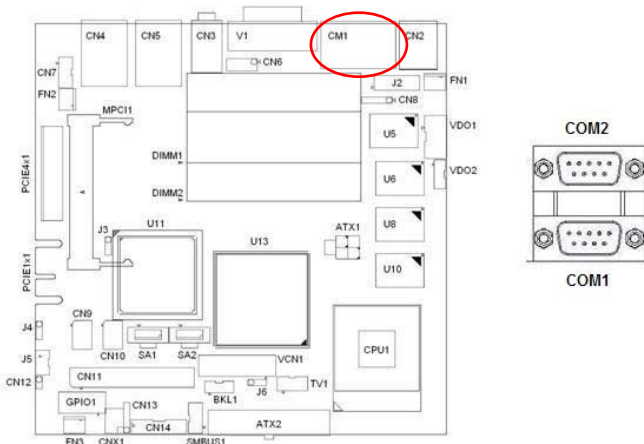

The DVMB-554E offers two serial ports. The user can use J2 to select among RS 232/422/485 modes for COM2. The default setting is RS 232 for both COM1 and COM2. These ports can connect to serial devices,

such as a mouse or printer, or to a communications network.

The IRQ and address ranges for both ports are fixed. However, if you want to disable the port or change these parameters later, you can do this in the system BIOS setup.

Different devices implement the RS-232/422/485 standards in different ways. If you are having problems with a serial device, be sure to check the pin assignments for the connector.

2.6 External PS/2 and Composite TV-Out (CN2)

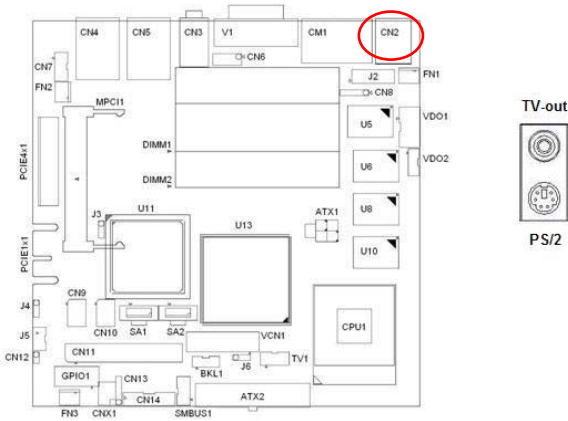

The DVMB-554E provides a PS/2 keyboard/mouse connector. A 6-pin mini-DIN connector is located on the rear face plate. It comes with an external Y cable to convert from the 6-pin mini-DIN connector to PS/2 keyboard and PS/2 mouse connection.

2.7 Fan Connector (FN1/FN2/FN3)

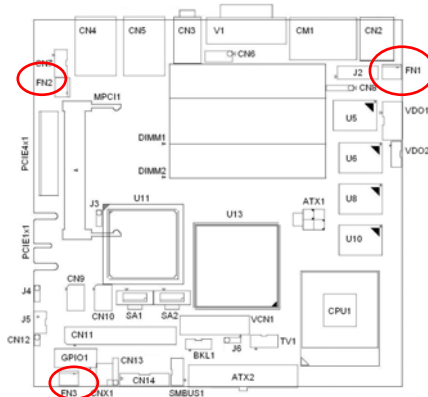

If fan is used, this connector supports cooling fans of 500 mA (6W) or less.

2.8 Front Panel Connectors (CNX1/CN13)

There are several external switches to monitor and control the DVMB-554.

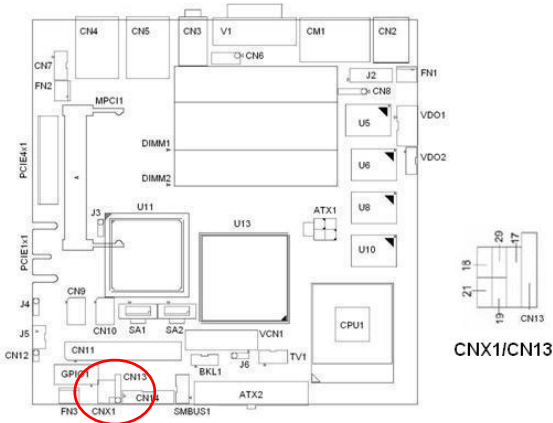

2.8.1 Power LED and Keyboard Lock (CN13)

CN13 is a 5-pin connector for the power LED. Refer to Appendix B for detailed information on the pin assignments. If a PS/2 or ATX power supply is used, the system's power LED status will be as indicated below:

Power mode	LED (PS/2 power)	LED (ATX power)
System On	On	On
System Suspend	Fast flashes	Fast flashes
System Off	Off	Slow flashes

2.8.2 External Speaker (CNX1-17)

It is a 4-pin connector for an external speaker. If there is no external speaker, the DVMB-554E provides an onboard buzzer as an alternative. To enable the buzzer, set pins 3-4 as closed.

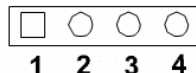

2.8.3 Reset Connector (CNX1-18)

Many computer cases offer the convenience of a reset button. Connect the wire from the reset button



2.8.4 HDD LED Connector (CNX1-19)

You can connect an LED to this connector to indicate when the HDD is active.



2.8.5 ATX Soft Power Switch (CNX1-21)

If your computer case is equipped with an ATX power supply, you should connect the power on/off button on your computer case to this connector. This connection enables you to turn your computer on and off.

2.8.6 SM Bus Connector (CNX1-29)

This connector is reserved for Advantech's SNMP-1000 HTTP/SNMP Remote System Manager. The SNMP-1000 allows users to monitor the internal voltages, temperature and fans from a remote computer through an Ethernet network.

CN29 can be connected to CN19 of SNMP-1000. Please be careful about the pin assignments, pin 1 must be connected to pin 1 and pin 2 to pin 2 on both ends of cable.

2.9 H/W Monitor Alarm (CN12)

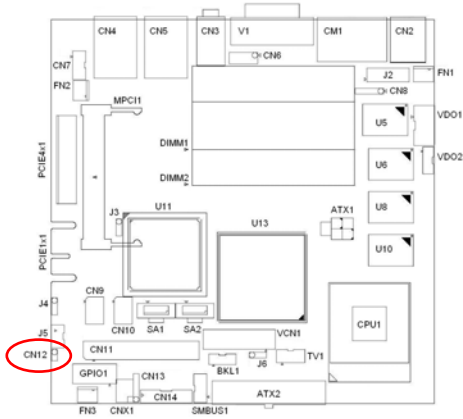

Close: Enable OBS Alarm

Open: Disable OBS Alarm

2.10 Line Out, Mic In Connector (CN3)

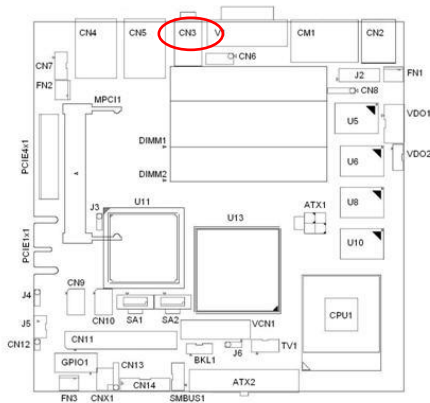

The Line Out is to output the audio signal to external audio device, like speakers or headphones. The Mic In is for the audio signal input via microphones.

2.11 Aux Line-In Connector (CN7)

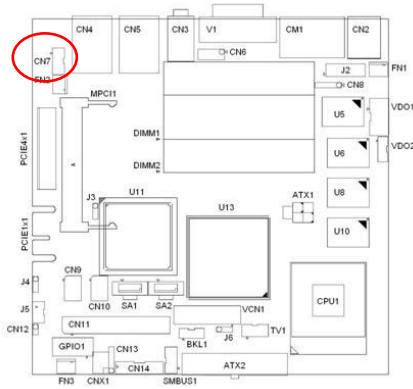

The connector is for audio devices with a Line-in connector.

2.12 Serial ATA Interface (SA1, SA2)

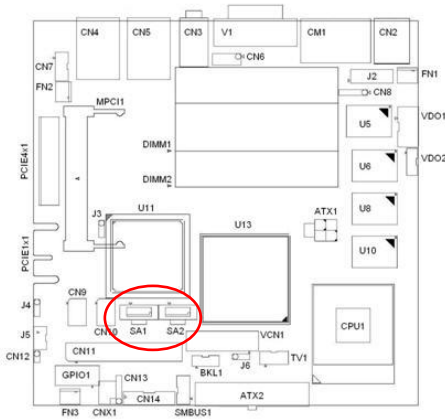

In addition to the EIDE interface (up to two devices), the DVMB-554E features a high performance serial ATA interface (up to 150 MB/s) which eases cabling to hard drives with thin and long cables.

2.13 DVA-210 Connector (VDO1)

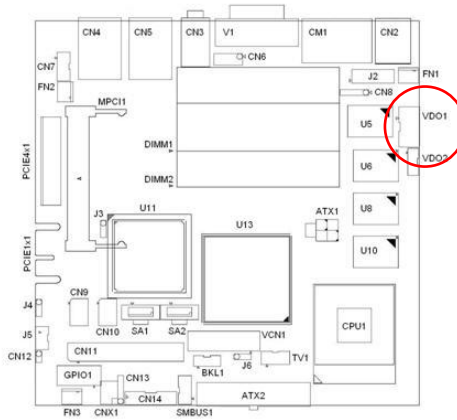

DVMB-554E has 4 video capture chips on board. So it can support up to 4 cameras. To be connecting with cameras, DVMB-554E needs to work with DVA-210 for video capture. DVA-210 is a 4 channel video module with BNC connectors and you can find it in DVMB-554E accessory box.

2.14 Auxiliary 4-pin power connector (ATX1)

To ensure the enough power is supplied to the motherboard, one auxiliary 4 pin power connector is available on the DVMB-554E. ATX1 must be used to provide sufficient 12 V power to ensure the stable operation of the system.

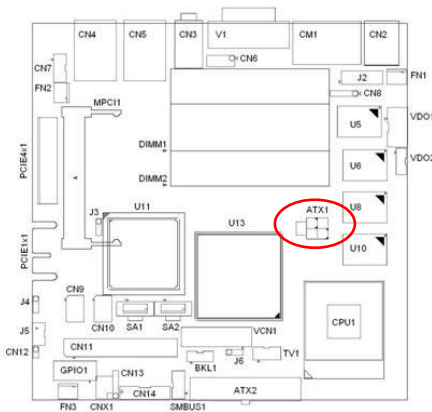

2.15 GPIO connector (GPIO1)

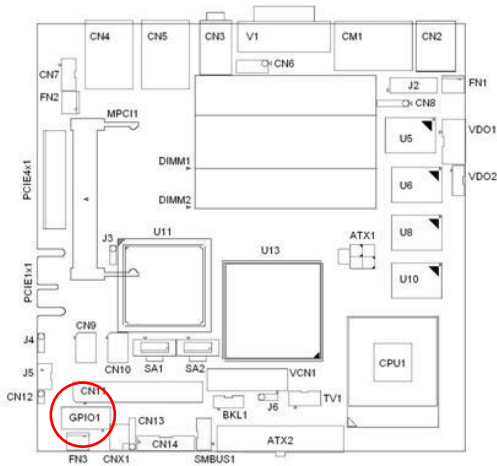

The DVMB-554E provides a GPIO interface, GPIO1, which is a 20 pin connector. Advantech provides SDK for this GPIO and have 7 pins for input and 8 pins for output. Please refer to pin assignments for GPIO1 connector as below.

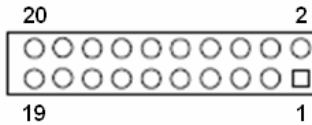

GPIO connector (GPIO1)

Pin	signal	pin	signal	pin	signal	pin	signal
1	+5V	6	Input	11	Output	16	Input
2	+5V	7	Output	12	Input	17	Output
3	Output	8	Input	13	Output	18	GND
4	Input	9	Output	14	Input	19	GND
5	Output	10	Input	15	Output	20	GND

2.16 LVDS connector (VCN1)

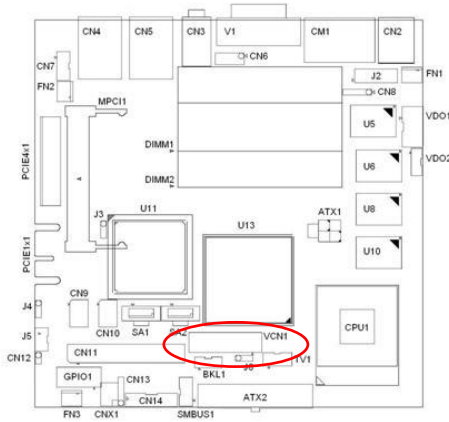

The DVMB-554E provides a LVDS interface supports 18 bits LCD panels. Pin assignments for LVDS connector VCN1 are listed as below.

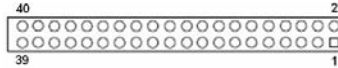

LVDS connector (VCN1)

Pin	signal	pin	signal	pin	signal	pin	signal
1	VDDS AFE	11	GND	21	OD2+	31	DDC_ CLK
2	VDDS AFE	12	GND	22	OD2+	32	DDC_ DAT
3	GND	13	OD1-	23	GND	33	GND
4	GND	14	OD1-	24	GND	34	GND
5	VDDS AFE	15	OD1+	25	OCK-	35	OD3-
6	VDDS AFE	16	OD1+	26	OCK-	36	OD3-
7	OD0-	17	GND	27	OCK+	37	OD3+
8	OD0-	18	GND	28	OCK+	38	OD3+
9	OD0+	19	OD2-	29	GND	39	HPLG
10	OD0+	20	OD2-	30	GND	40	VCON

2.17 LCD Inverter Power connector (BKL1)

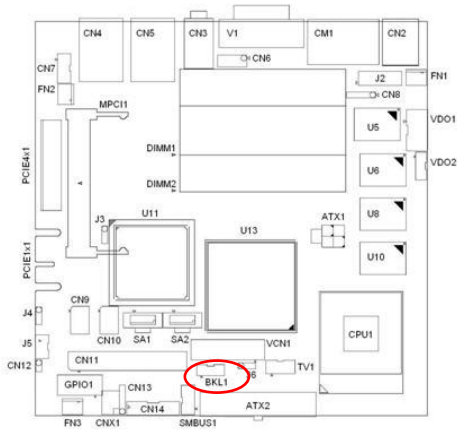

VP1 is connected to Inverter which can provide power to LCD Panel. The DVMB-554E can provide a LVDS display.

3

BIOS Setup

Chapter 3 Award BIOS Setup

3.1 Introduction

Award's BIOS ROM has a built-in setup program that allows users to modify the basic system configuration. This type of information is stored in battery backed-up memory (CMOS RAM) so that it retains the setup information when the power is turned off.

3.1.1 CMOS RAM Auto-backup and Restore

The CMOS RAM is powered by an onboard button cell battery. When you finish BIOS setup, the data in CMOS RAM will be automatically backed up to Flash ROM. If operation in harsh industrial environments causes a soft error, BIOS will recheck the data in CMOS RAM and automatically restore the original data in Flash ROM to CMOS RAM for booting.

Note: If you intend to change the CMOS setting without restoring the previous backup, you have to click on "DEL" within two seconds of the "CMOS checksum error..." display screen message appearing. Then enter the "Setup" screen to modify the data. If the "CMOS checksum error..." message appears again and again, please check to see if you need to replace the battery in your system.

3.2 Entering Setup

Turn on the computer and press to enter the BIOS setup.

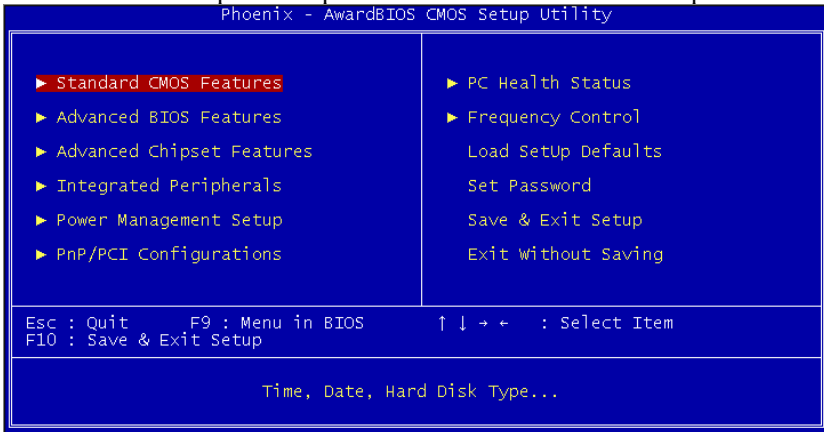

Figure 3.1: Award BIOS Setup initial screen

3.3 Standard CMOS Setup

3.3.1 Date

The date format is <week>, <month>, <day>, <year>.

3.3.2 Time

The time format is <hour> <minute> <second>, based on the 24-hour clock.

3.3.3 IDE channel 0/1 Master/Slave

- **IDE HDD Auto-Detection:** Press “Enter” to select this option for automatic device detection.
- **IDE Device Setup:**
 - Auto:** Automatically detects IDE devices during POST
 - None:** Select this when no IDE device is used. The system will skip the auto-detection step to make system start up faster.
 - Manual:** User can manually input the correct settings.
- **Access Mode:** The options are CHS/LBA/Large/Auto
- **Capacity:** Capacity of currently installed hard disk.
- **Cylinder:** Number of cylinders

- **Head:** Number of heads
- **Precomp:** Write precomp
- **Landing Zone:** Landing zone
- **Sector:** Number of sectors

3.3.4 Halt On

This category determines whether system start-up will halt or not when an error is detected during power up.

The options are: No Errors/All Errors/All, But Keyboard/All, But Diskette/All, But Disk/Key

3.3.5 Memory

This category displays base memory, extended memory, and total memory detected during POST (Power On Self Test).

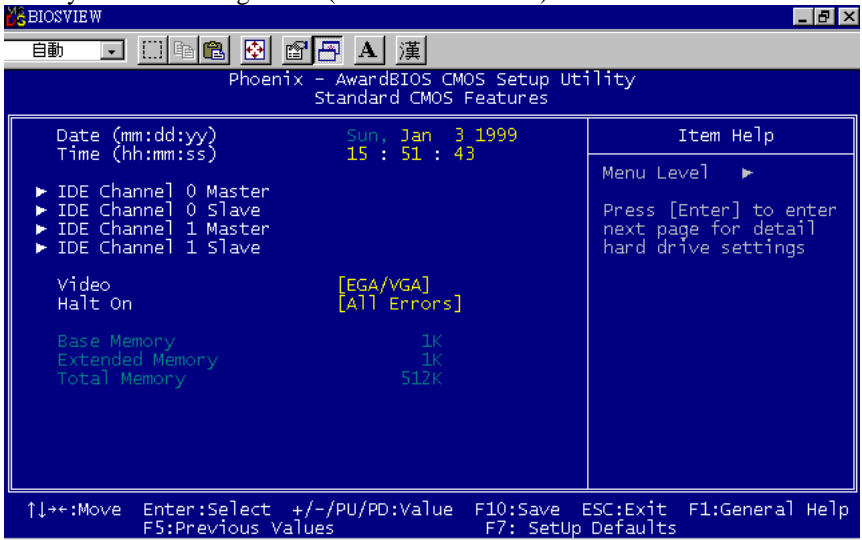

Figure 3.2: Standard CMOS Features Screen

3.4 Advanced BIOS Features

The “Advanced BIOS Features” screen appears when choosing the “Advanced BIOS Features” item from the “Initial Setup Screen” menu. It allows the user to configure the DVMB-554E according to his particular requirements. Below are some major items that are provided in the Advanced BIOS Features screen. A quick booting function is provided for your convenience. Simply enable the Quick Booting item to save yourself valuable time.

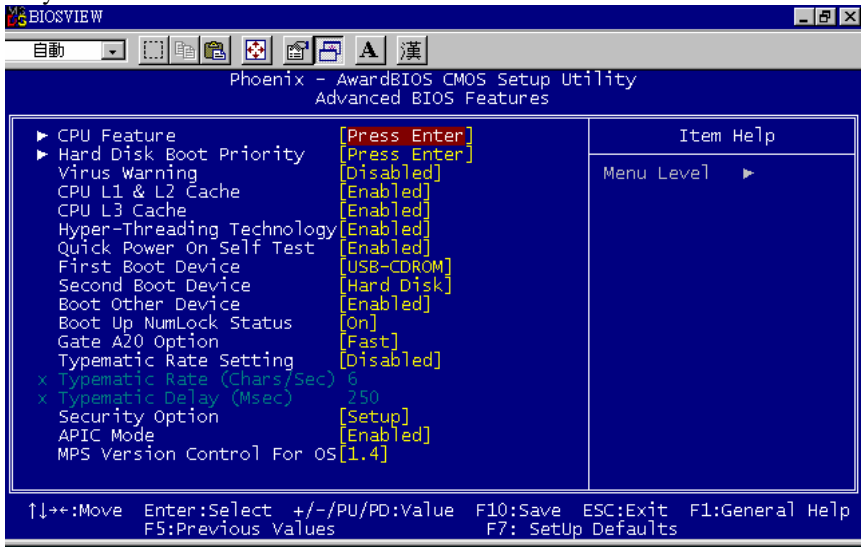

Figure 3.3: Advanced BIOS features screen

3.4.1 CPU Features

Delay Prior to thermal

This feature controls the activation of the Thermal Monitor's automatic mode. It allows you to determine when the Pentium 4's Thermal Monitor should be activated in automatic mode after the system boots. For example, with the default value of 16 Minutes, the BIOS activates the Thermal Monitor in automatic mode 16 minutes after the system starts booting up. The choices are 4 Min, 8 Min, 16 Min, and 32 Min.

C1E Function

CPU C1E Function select. Default value is Auto

Execute Disable Bit

When disabled, forces the XD feature flag to always return 0.

3.4.2 Hard Disk Boot Priority

Set hard disk boot device priority.

3.4.3 Virus Warning

Enables or disables the virus warning.

3.4.4 CPU L1, L2 & L3 Cache

Enabling this feature speeds up memory access. The commands are "Enabled" or "Disabled."

3.4.5 Quick Power On Self Test

This allows the system to skip certain tests to speed up the boot-up procedure.

3.4.6 First/Second Boot Device

The BIOS tries to load the OS from the devices in the sequence set here. The options are: "Floppy", "LS120", "CDROM", "Hard Disk", "ZIP100", "USB-FDD", "USB-ZIP", "USBCDROM", "LAN1", "LAN2" and "Disabled".

3.4.7 Boot Other Device

Use this to boot another device. The options are "Enabled" and "Disabled".

3.4.8 Boot Up NumLock Status

Sets the boot up status Num Lock. The options are “On” and “Off”.

3.4.9 Gate A20 Option

“Normal”: A pin in the keyboard controller controls GateA20. Fast (Default) lets chipset control GateA20.

3.4.10 Typematic Rate Setting

The typematic rate is the rate key strokes repeat as determined by the keyboard controller. The commands are “Enabled” or “Disabled”. Enabling allows the typematic rate and delay to be selected.

3.4.11` Typematic Rate (Chars/Sec)

The BIOS accepts the following input values (characters/second) for typematic rate: 6, 8, 10, 12, 15, 20, 24, and 30.

3.4.12 Typematic Delay (msec)

Typematic delay is the time interval between the appearances of two consecutive characters, when the key is continuously depressed. The input values for this category are: 250, 500, 750, and 1000 (ms).

3.4.13 Security Option

This category determines whether the password is required when the system boots up or only when entering setup. The options are:

- **System:** The system will not boot, and access to Setup will be also denied unless the correct password is entered at the prompt.
- **Setup:** The system will boot, but access to Setup will be denied unless the correct password is entered at the prompt.

Note: To disable security, select PASSWORD SETTING in the main menu. Then, you will be asked to enter a password. Simply press <Enter> to disable security. When security is disabled, the system will boot and you can enter Setup freely.

3.4.14 APIC Mode

This setting allows you to enable the APIC mode. The choices are “Disabled” or “Enabled.”

3.4.15 MPS Version Control For OS

This specifies the version of the Multiprocessor Specification (MPS) to be used. Version 1.4 has extended configuration tables to improve support for multiple PCI bus configurations and provide future expandability - use this for NT, and possibly Linux. It is also required for a secondary PCI bus to work without the need for a bridge. Leave it as 1.1 for older server Operating Systems.

3.5 Advanced Chipset Features

By choosing the “Advanced Chipset Features” option from the “Initial Setup Screen” menu, the screen below will be displayed. This sample screen contains the manufacturer’s default values for the DVMB-554E, as shown in Figure 3-5:

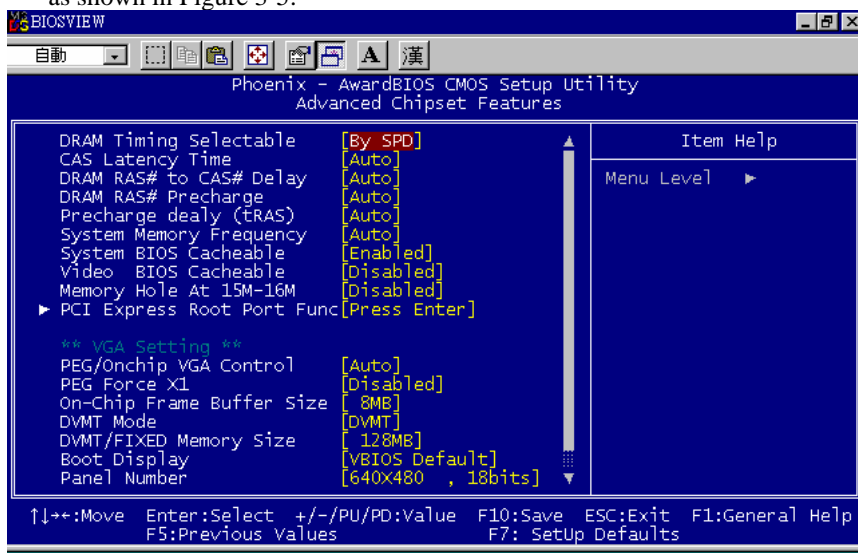

Figure 3.5: Advanced chipset features screen (a)

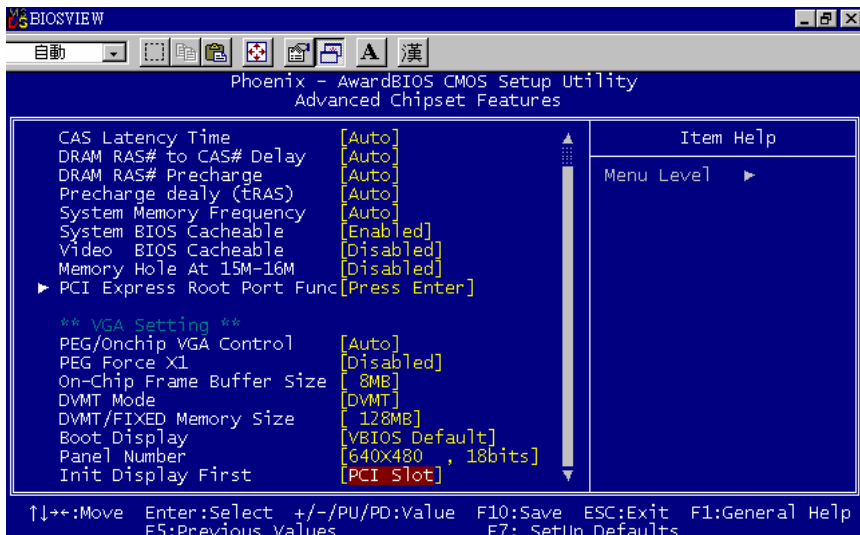

Figure 3.5: Advanced chipset features screen (b)

Note: DRAM default timings have been carefully chosen and should ONLY be changed if data is being lost. Please first contact technical support.

3.5.1 DRAM Timing Selectable

This item allows you to control the DRAM speed. The selections are “Manual” or “By SPD”.

3.5.2 CAS Latency Time

When DRAM Timing Selectable is set to [Manual], this field is adjustable. This controls the CAS latency, which determines the time interval between SDRAM starting a read command and receiving it. The options are [3T], [4T], [5T], and [Auto].

3.5.3 DRAM RAS# to CAS# Delay

When DRAM Timing selectable is set to [Manual], this field is adjustable. When DRAM is refreshed, the rows and columns are addressed separately. This setup item allows user to determine the timing of the transition from RAS (row address strobe) to CAS (column address strobe). The less the clock cycles are, the faster the DRAM speed is. Setting options are [2T] to [5T], and [Auto].

3.5.4 DRAM RAS# Precharge

When the DRAM Timing Selectable is set to [Manual], this field is adjustable. This setting controls the number of cycles for Row Address Strobe (RAS) to be allowed to precharge. If no sufficient time is allowed for the RAS to accumulate its charge before DRAM refresh, refreshing may be incomplete and DRAM may fail to retain data. This item applies only when synchronous DRAM is installed in the system. Setting options are [2T] to [5T], and [Auto].

3.5.5 Precharge Delay (t RAS)

This item allows you to select the value in this field, depending on whether the board has paged DRAMs or EDO (extended data output) DRAMs. The choices are: "4" to "15" and "Auto".

3.5.6 System Memory Frequency

To adjust the frequency of memory. The choices are: "533MHz", "667MHz" and "Auto".

3.5.7 System BIOS Cacheable

Selecting "Enabled" allows caching of the system BIOS ROM at F0000h-FFFFFh, resulting in better system performance. However, if any program writes data to this memory area, a system error may occur. The Choices are "Enabled", and "Disabled".

3.5.8 Video BIOS Cacheable

Selecting "Enabled" allows caching of the video BIOS, resulting in better system performance. However, if any program writes to this memory area, a system error may occur. The choices are "Enabled", and "Disabled".

3.5.9 Memory Hole At 15M-16M

Enabling this feature reserves 15 MB to 16 MB memory address space for ISA expansion cards that specifically require this setting. This makes memory from 15 MB and up unavailable to the system. Expansion cards can only access memory up to 16 MB. The default setting is "Disabled".

3.5.10 PCI-Express Root Port Func

PCI Express Port 1/2/3/4

The default setting is "Auto." The choices are "Enabled," "Disabled," and "Auto."

PCI-E Compliancy Mode

This allows the user to select the PCI-E compliant mode. The options are [v1.0], and [v1.0a].

3.5.11 PEG / Onchip VGA Control

Use this field to select PEG or Onchip VGA. The default is AUTO.

3.5.12 On-Chip Frame Buffer Size

The On-Chip Frame Buffer Size can be set to 1 MB or 8 MB. This memory is shared with the system memory.

3.5.13 DVMT Mode

Displays the active system memory mode.

3.5.14 DVMT / FIXED Memory Size

Specify the size of DVMT / FIXED system memory to allocate for video memory.

3.5.15 Boot Display

Choose the boot display device. The default setting is "Auto". The choices are "VBIOS Default", "CRT", "LFP" and "LFP+CRT".

3.5.16 Panel Number

These fields allow you to select the LCD Panel type. The default values for these ports are:

- 640x480, 18bit SC
- 800x600, 18bit SC
- 1024x768, 18bit SC
- 1028x1024, 18bit DC

3.5.17 Init Display First

Choose the first display interface to initiate while booting. The choice is “PCI Slot” or “Onboard”.

3.6 Integrated Peripherals

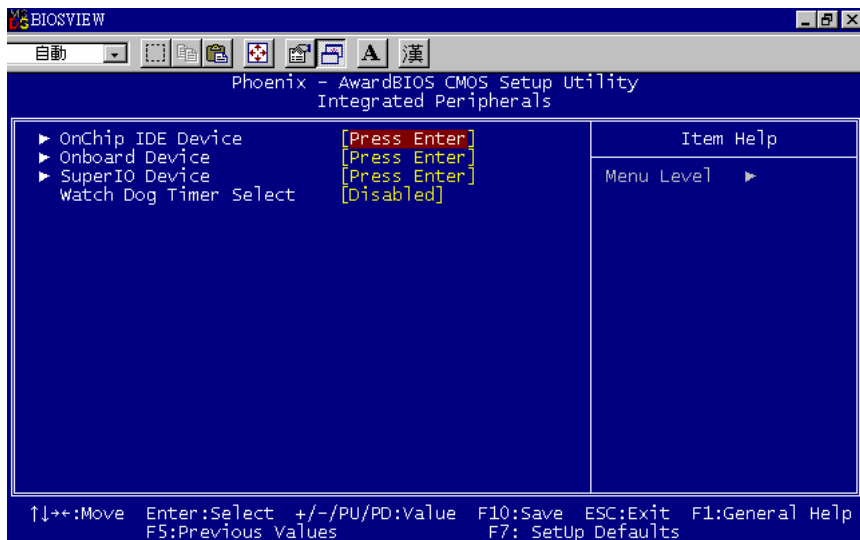

Figure 3.6: Integrated peripherals

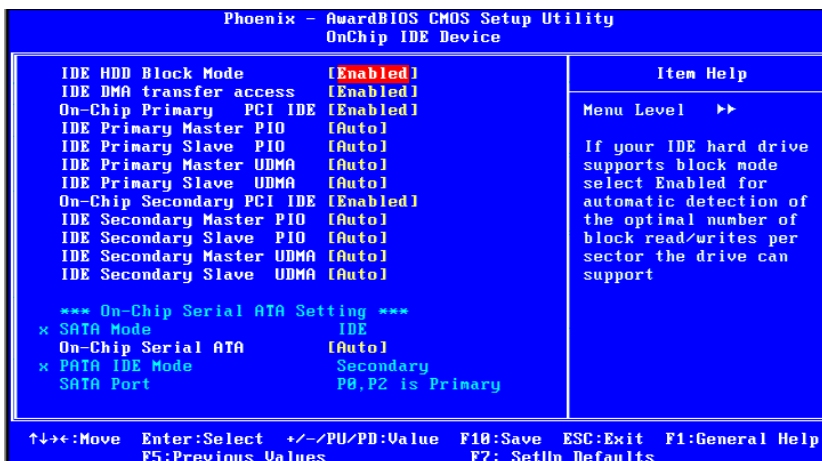

Figure 3.7: On-Chip IDE Device

3.6.1 IDE HDD Block Mode

If your IDE hard drive supports block mode select Enabled for automatic detection of the optimal number of block read/writes per sector the drive can support.

3.6.2 IDE DMA Transfer Access

Use this field to enable or disable IDE DMA transfer access.

3.6.3 On-Chip Primary / Secondary IDE Device

IDE Primary Master/Slave PIO/UDMA Mode (Auto). The channel has both a master and a slave, making four IDE devices possible. Because two IDE devices may have a different Mode timing (0, 1, 2, 3, 4), it is necessary for these to be independent. The default setting “Auto” will allow auto detection to ensure optimal performance.

3.6.4 SATA Mode

The setting choices for the SATA Mode are IDE, RAID and AHCI Mode. Select [IDE] if you want to have SATA function as IDE. Select [AHCI] for Advanced Host Controller Interface (AHCI) feature, with improved SATA performance and native command queuing. Select [RAID] to use SATA for RAID.

Note: Please refer to the PDF-format Intel(R) Matrix Storage Technology Quickstartguide and Intel(R) Matrix Storage Manager User's Manual in this CD (in the MANUAL folder) to know the necessary steps to build and configure your RAID 0, 1 system using Intel(R) Matrix Storage Technology and Matrix

Storage Manager.

3.6.5 On-Chip Serial ATA

Choose the status of serial ATA. The default setting is “Auto” which lets the system arrange all parallel and serial ATA resources automatically. The “Disabled” setting disables the SATA controller. The “Combined Mode” combines PATA and SATA, and maximum of 2 IDE drives in each channel. The “Enhanced Mode” enables both SATA and PATA, and a maximum of 6 IDE drives are supported. The “SATA Only” setting means SATA is operating in legacy mode.

3.6.6 PATA IDE Mode

This item shows the parallel ATA channel. It is Secondary.

3.6.7 SATA Port

The PATA IDE mode must to be set to Secondary and SATA will display

“P0, P2 is Primary”. It means SATA0 and SATA2 act as Primary Channel. We have one configuration with this setting by spec. and can't swap the channel.

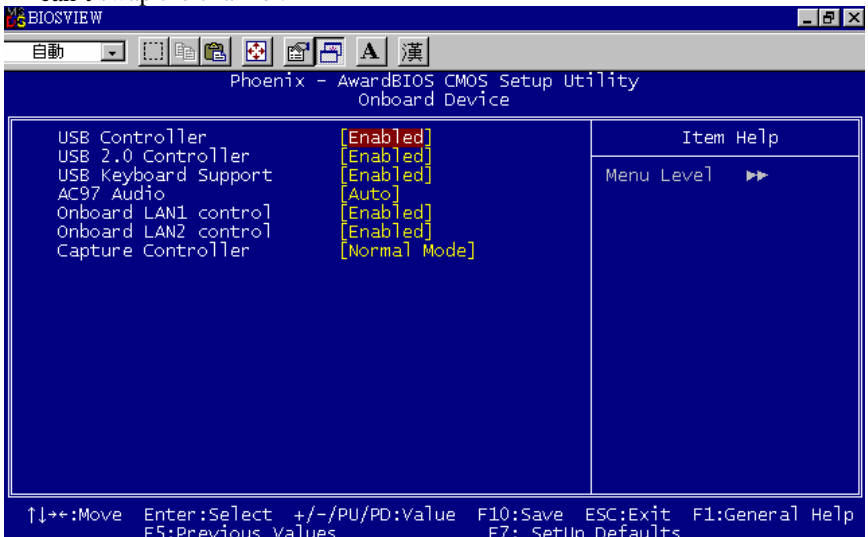

Figure 3.8: Onboard Device

3.6.8 USB Controller

Select Enabled if your system contains a Universal Serial Bus (USB) controller and you have USB peripherals. The choices are “Enabled” and

“Disabled”.

3.6.9 USB 2.0 Controller

This entry is to disable/enable the USB 2.0 controller only. The BIOS itself may/may not have high-speed USB support. If the BIOS has high speed USB support built in, the support will automatically turn on when a high speed device is attached. The choices are “Enabled” or “Disabled”.

3.6.10 USB Keyboard / Mouse Support

Select Enabled if you plan to use an USB keyboard. The choices are “Enabled” and “Disabled”.

3.6.11 AC97 Audio

Select “Disable” if you do not want to use AC-97 audio. Options are “Auto”, and “Disabled”.

3.6.12 Onboard LAN1 Control

Options are “Enabled” and “Disabled”. Select “Disabled” if you don’t want to use onboard LAN controller1.

3.6.13 Onboard LAN2 Control

Options are “Enabled” and “Disabled”. Select Disabled if you don’t want to use the onboard LAN controller2.

Note: Correct sequence of onboard Lan controllers(Lan1 & Lan2) shows in the "Onboard Device" BIOS view.

3.6.14 Capture Controller

Options are “Normal Mode” and “Enhanced Mode”. Select Enhanced Mode if you want to have more effective video capture performance. Default setting is Normal Mode.

Note: *DRAM default timings have been carefully chosen and should ONLY be changed if data is being lost. Please first contact technical support.*

Super I/O Device:

3.6.15 Onboard Serial Port 1

The settings are “3F8/IRQ4”, “2F8/IRQ3”, “3E8/IRQ4”, “2E8/IRQ3”, and “Disabled” for the on-board serial connector.

3.6.16 Onboard Serial Port 2

The settings are “3F8/IRQ4”, “2F8/IRQ3”, “3E8/IRQ4”,

“2E8/IRQ3”, and “Disabled” for the on-board serial connector.

3.6.17 UART Mode Select

This item allows you to select UART mode. The choices: “IrDA”, “ASKIR”, and “Normal”.

3.6.18 RxD, TxD Active

This item allows you to determine the active level of the RxD and TxD serial lines. The Choices: “Hi, Hi”, “Lo, Lo”, “Lo, Hi”, and “Hi, Lo”.

3.6.19 IR Transmission Delay

This item allows you to enable/disable IR transmission delay. The choices are “Enabled” and “Disabled”.

3.6.20 UR2 Duplex Mode

This item allows you to select the IR half/full duplex function. The choices are “Half” and “Full”.

3.6.21 Use IR Pins

The choices are “Rx2D2, Tx2D2” and “IR-Rx2Tx2”.

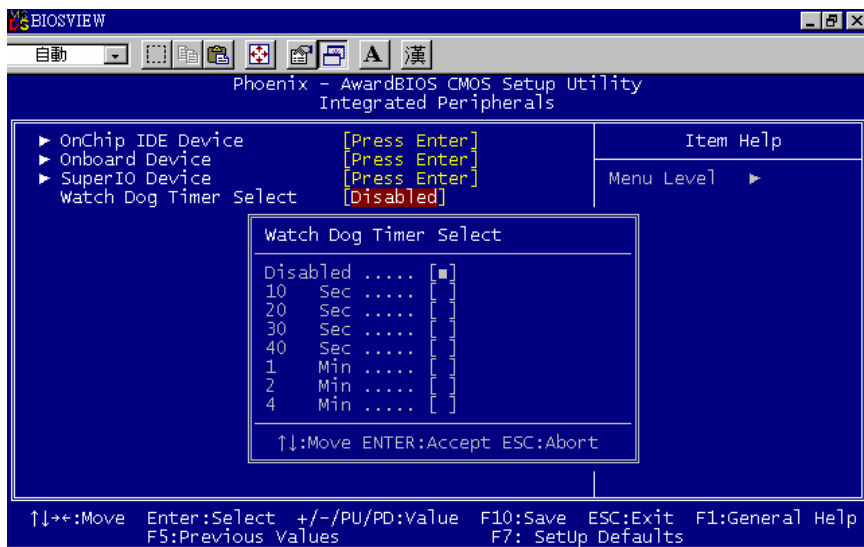

Figure 3.9: Watch Dog Timer

3.6.22 Watch Dog Timer Select

Allow User select watch Dog time or disable..

3.7 Power Management Setup

The power management setup controls the single board computer's “green” features to save power. The following screen shows the manufacturer's defaults.

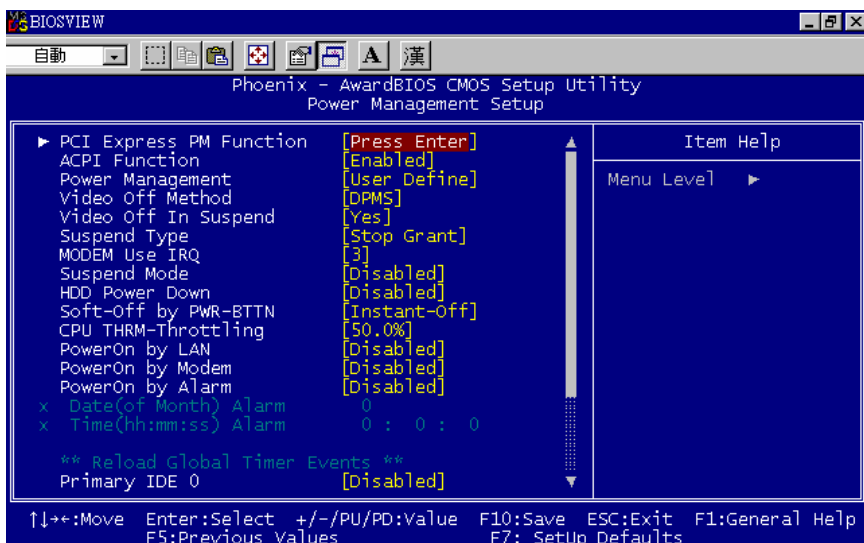

Figure 3.10: Power management setup screen (a)

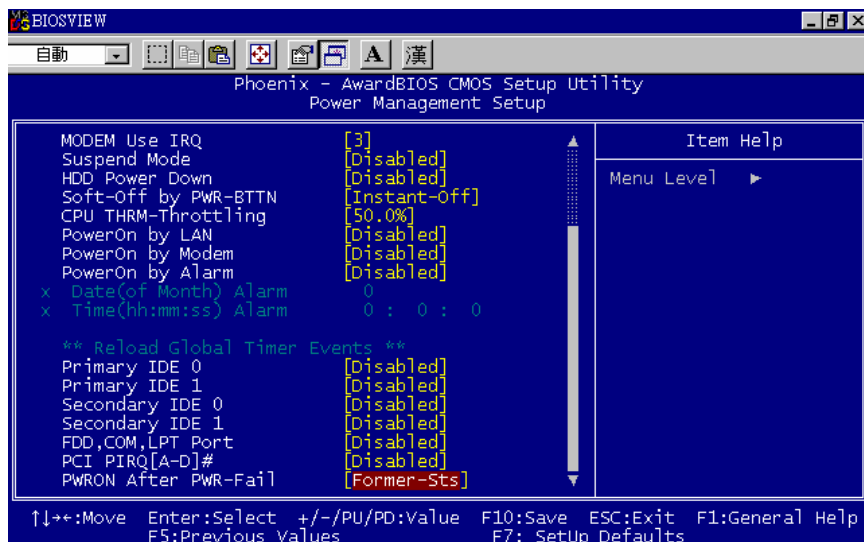

Figure 3.10: Power management setup screen (b)

3.7.1 PCI Express PM Function

This allow you to control Power On by onboard LAN chip feature.

3.7.2 ACPI Function

The choices are: “Enabled” and “Disabled”.Power Management

This category allows you to select the type (or degree) of power saving and is directly related to the following modes:

- HDD Power Down
- Suspend Mode

There are three selections for Power Management, and they have fixed mode settings.

Saving Mode	Function
Min Saving	Minimum power management., Suspend Mode = 1 hr., and HDD Power Down = 15 min.
Max Saving	Maximum power management., Suspend Mode = 1 min., and HDD Power Down = 1 min.
User Defined (Default)	Allows you to set each mode individually. When not disabled, each of the ranges are from 1 min. to 1 hr. except for HDD Power Down which ranges from 1 min. to 15 min., and disabled.

3.7.3 Power Management

This item allows user to select system power saving mode.

- Min Saving Minimum power management. Suspend Mode=1 hr.
- Max Saving Maximum power management. Suspend Mode=1 min.
- User Define Allows user to set each mode individually. Suspend Mode= Disabled or 1 min ~1 hr.

3.7.4 Video Off Method

Use this to select the method to turn off the video. The choices are “Blank Screen”, “V/H SYNC+ Blank”, and “DPMS”.

3.7.5 Video Off In Suspend

When the system is in suspend mode, the video will turn off. The choices are “No” and “Yes”.

3.7.6 Suspend Type

The choices are “Stop Grant” and “PwrOn Suspend”.

3.7.7 Modem Use IRQ

This determines the IRQ that the MODEM can use. The choices are “3”, “4”, “5”, “7”, “9”, “10”, “11”, and “NA”.

3.7.8 Suspend Mode

This item allows user to determine the time of system inactivity, all devices except the CPU will be shut off.

3.7.9 HDD Power Down

This item allows user to determine the time of system inactivity, the hard disk drive will be powered down.

3.7.10 Soft-Off by PWR-BTTN

If you choose “Instant-Off”, then pushing the ATX soft power switch button once will switch the system to “system off” power mode. You can choose “Delay 4 sec”. If you do, then pushing the button for more than 4 seconds will turn off the system, whereas pushing the button momentarily

(for less than 4 seconds) will switch the system to “suspend” mode.

3.7.11 PowerOn by LAN

This item allows you to power on the system by LAN. The choices are “Enabled” and “Disabled”.

3.7.12 CPU THRM-Throttling

This option controls the CPU speed as a percentage of regular power. The choices are 87.5%, 75%, 62.5%, 50%, 37.5%, 25% .12% and 12.5%.

3.7.13 PowerOn by Modem

To enabled or disable the function to power on the system via a Modem connection from a remote host. The choice “Enabled” and “Disabled”.

3.7.14 PowerOn by Alarm

The choices are “Enabled” and “Disabled”. Fields that follow below indicate date of current month and time of alarm settings, if enabled.

3.7.15 Primary IDE 0 (1) and Secondary IDE 0 (1)

When Enabled, the system will resume from suspend mode if Primary IDE 0 (1) or Secondary IDE 0 (1) becomes active. The choices are “Enabled” and “Disabled”.

3.7.16 FDD, COM, LPT PORT

When Enabled, the system will resume from suspend mode if the FDD, interface, COM port, or LPT port is active. The choices are “Enabled” and “Disabled”.

3.7.17 PCI PIRQ [A-D]#

When Enabled, the system resumes from suspend mode if an interrupt occurs. The choices are “Enabled” and “Disabled”.

3.7.18 PWRON After PWR-Fail

Use this to set up the system after power failure. The “Off” setting keeps the system powered off after power failure, the “On” setting boots up the system after failure, and the “Former-Sts” returns the system to the status before power failure.

3.8 PnP/PCI Configurations

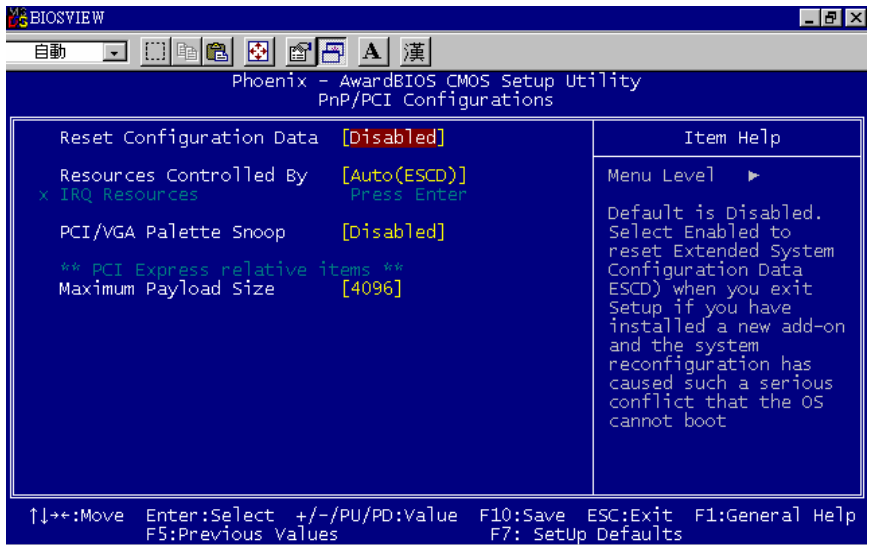

Figure 3.11: PnP/PCI configurations screen

3.8.1 Reset Configuration Data

The default is Disabled. Select Enabled to reset Extended System Configuration Data (ESCD) if you have installed a new add-on card, and system configuration is in such a state that the OS cannot boot.

3.8.2 Resources Controlled By

The commands here are “Auto(ESCD)” or “Manual”. Choosing “Manual” requires you to choose resources from the following sub-menu. “Auto(ESCD)” automatically configures all of the boot and Plug and Play devices, but you must be using Windows 95 or above.

3.8.3 PCI / VGA Palette Snoop

This is set to “Disabled” by default.

3.8.4 Maximum Payload Size

This allows you to set the maximum TLP payload size for PCI Express devices. The options are [128 bytes], [256 bytes], [512 bytes], [1024 bytes], [2048 bytes], and [4096 bytes].

3.9 PC Health Status

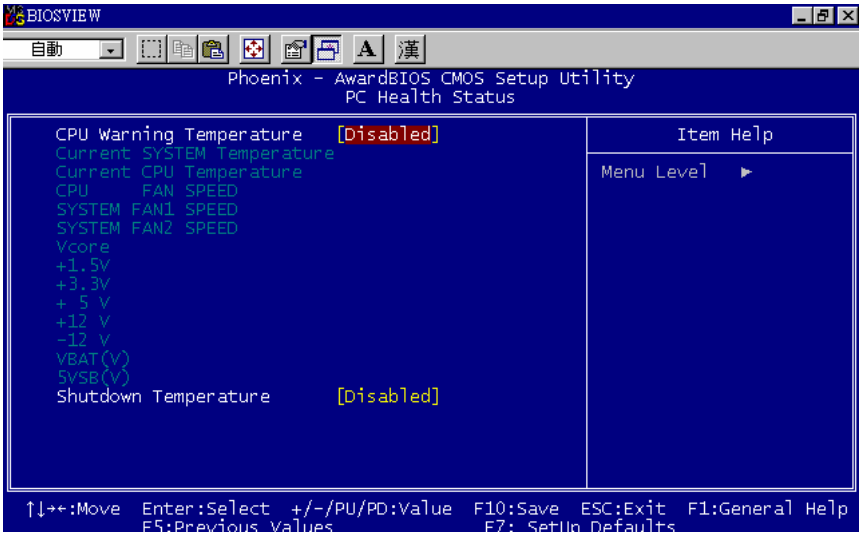

Figure 3.12: PC Health Status Screen

3.9.1 CPU Warning Temperature

This item will prevent the CPU from overheating. The choices are “Disabled”, “60C/140F”, “63C/145F”, “66C/151F”, “70C/158F”, “75C/167F”, “80C/176F”, “85C/185F”, “90C/194F”, and “95C/205F”.

3.9.2 Current System Temperature

This shows you the current temperature of system.

3.9.3 Current CPU Temperature

This shows the current CPU temperature.

3.9.4 CPU FAN Speed

This shows the current CPU FAN operating speed.

3.9.5 System FAN 1 / 2 Speed

This shows the current System FAN operating speed.

3.9.6 VCORE and Other Voltages

This shows the voltage of VCORE, +1.5V, +3.3, +5V, +12V, -12V, -5V, VBAT(V), and 5VSB(V).

3.9.7 Shutdown Temperature

This item enables users to set the limitation of CPU temperature, the range is from 85°C through 100°C.

3.10 Frequency / Voltage Control

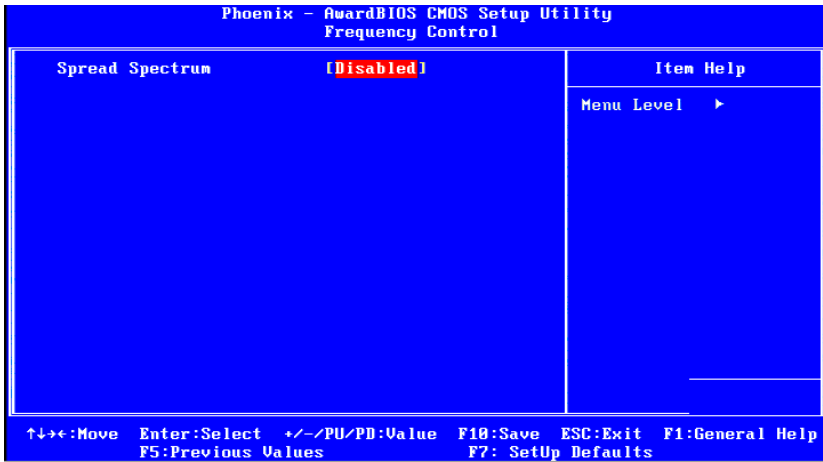

Figure 3.14: Spread Spectrum Control screen

3.10.1 Spread Spectrum

This setting allows you to reduce EMI by modulating the signals the CPU generates so that the spikes are reduced to flatter curves. This is achieved by varying the frequency slightly so that the signal does not use any particular frequency for more than a moment. The choices are “Disabled” and “Enabled”.

3.11 Password Setting

Follow these steps to change the password.

1. Choose the “Set Password” option from the “Initial Setup Screen” menu and press <Enter>. The screen displays the following message:



2. Press <Enter>.
3. If the CMOS is good and this option has been used to change the default password, the user is asked for the password stored in the CMOS. The screen displays the following message:

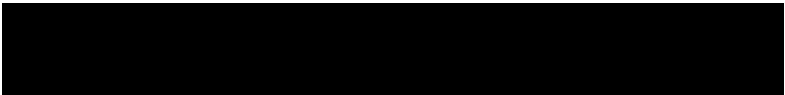

4. Type the current password and press <Enter>.
5. After pressing <Enter> (ROM password) or the current password (user-defined), you can change the password stored in the CMOS. The password must be no longer than eight (8) characters.

Remember, to enable the password setting feature, you must first select either “Setup” or “System” from the “Advanced BIOS Features” menu.

3.12 Save & Exit Setup

If you select this and press <Enter>, the values entered in the setup utilities will be recorded in the CMOS memory of the chipset. The processor will check this every time you turn your system on and compare this to what it finds as it checks the system. This record is required for the system to operate.

3.13 Exit Without Saving

Selecting this option and pressing <Enter> lets you exit the setup program without recording any new values or changing old ones.

4

Chipset Installation

Chapter 4 Chipset Installation

4.1 Before you begin

To facilitate the installation of the enhanced display drivers and utility software, read the instructions in this chapter carefully. The drivers for the DVMB-554E are located on the software installation CD. The Intel® Chipset Software Installation Utility is not required on any systems running Windows NT 4.0. Updates are provided via Service Packs from Microsoft*.

Note: *The files on the software installation CD are compressed. Do not attempt to install the drivers by copying the files manually. You must use the supplied SETUP program to install the drivers.*

Before you begin, it is important to note that most display drivers need to have the relevant software application already installed in the system prior to installing the enhanced display drivers. In addition, many of the installation procedures assume that you are familiar with both the relevant software applications and operating system commands. Review the relevant operating system commands and the pertinent sections of your application software's user manual before performing the installation.

4.2 Introduction

The Intel® Chipset Software Installation (CSI) utility installs the Windows INF files that outline to the operating system how the chipset components will be configured. This is needed for the proper functioning of the following features:

- Core PCI PnP services
- IDE Ultra ATA 100/66/33 and Serial ATA interface support
- USB 1.1/2.0 support (USB 2.0 driver needs to be installed separately for Win98)
- Identification of Intel® chipset components in the Device Manager

- Integrates superior video features. These include filtered sealing of 720 pixel DVD content, and MPEG-2 motion compensation for software DVD

Note: *This utility is used for the following versions of Windows system, and it has to be installed before installing all the other drivers:*

- Windows 2000
- Windows XP

4.3 Windows XP Driver Setup

1. Insert the driver CD into your system's CD-ROM drive. All the drivers of DVMB-554E are under DVMB-554E_CD\01_DVMB-554E_Driver.
2. For the driver of Intel 945GM chipset is under DVMB-554E_CD\ 01_DVMB-554E_Driver\01_945 chipset. Double click the icon which is in the folder to install driver. To take Windows XP as example.
3. Click “Next” when you see the following message.

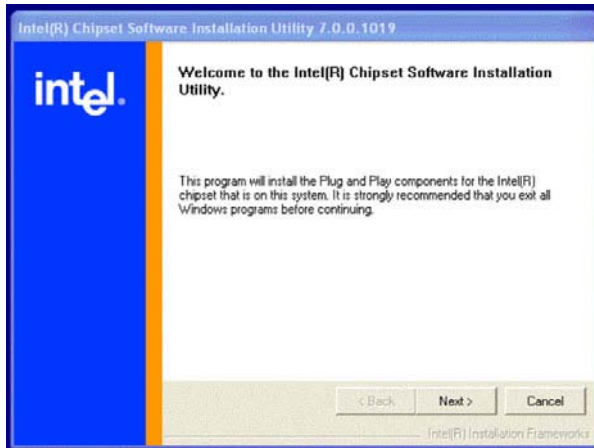

4. Click “Yes” when you see the following message.

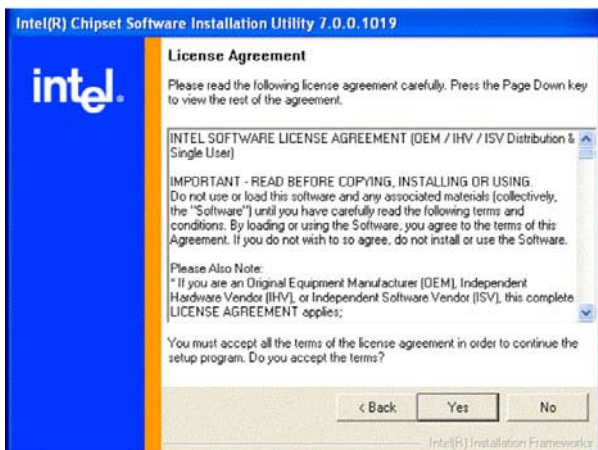

5. Click “Next” when you see the following message.

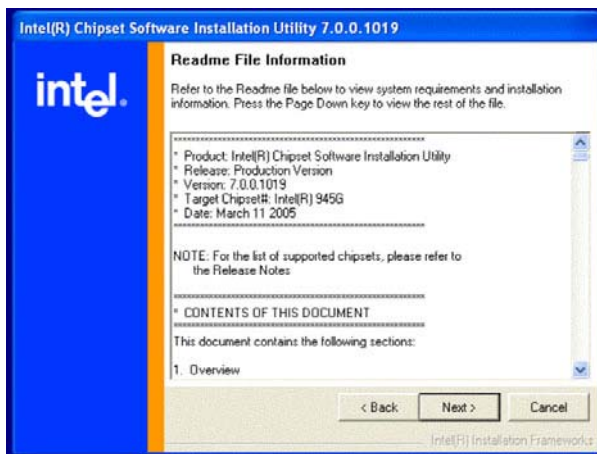

- When the following message appears, click “Finish” to complete the installation and restart Windows.

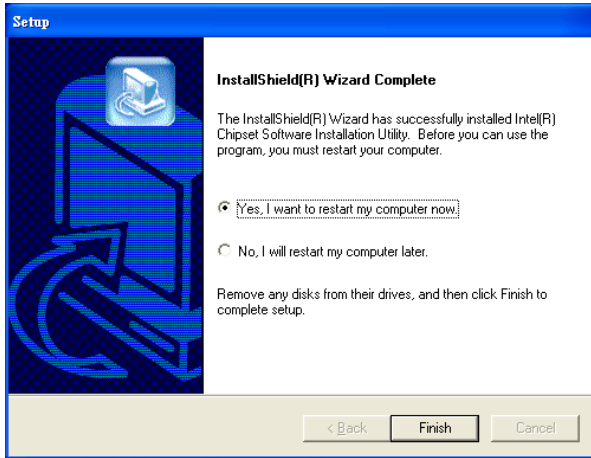

5

VGA Setup

Chapter 5 VGA Setup

5.1 Introduction

The Intel 945GM integrated graphics controller provides an analog display port, LVDS and TV-out interface. You need to install the VGA driver to enable the function.

The Intel 945GM integrated graphics controller includes the following features.

- **Intel Graphics Media Accelerator 950:** Incorporating the latest Microsoft* DirectX*9 support capabilities, it allows software developers to create lifelike environments and characters. Dual independent display, enhanced display modes for widescreen flat panels, and optimized 3D support deliver an intense and realistic visual experience without requiring a separate graphics card.
- **Intel Dynamic Video Memory Technology (DVMT3.0):** DVMB-554E handles diverse applications by providing the maximum availability of system memory for general computer usage, while supplying additional graphics memory when a 3D-intensive application requests it. The amount of video memory is dependent upon the amount of pre-allocated memory set for your system plus something called Dynamic Video Memory Technology (DVMT).
- **LVDS Interface:** DVMB-554E provide 18-bit dual channel LVDS interface supporting up to WUXGA(1600X1200) panel resolution.
- **TV-Out:** DVMB-554E Supports PAL/ NTSC TV systems

5.2 Windows XP Driver Setup

Insert the driver CD into your system's CD-ROM drive and find Graphic driver under DVMB-554E_CD\01_DVMB-554E_Driver\ 02_Graphics.

The following installation procedure is for Windows XP. For other operating systems please do a manual installation.

1. Click “Next” to continue the installation.

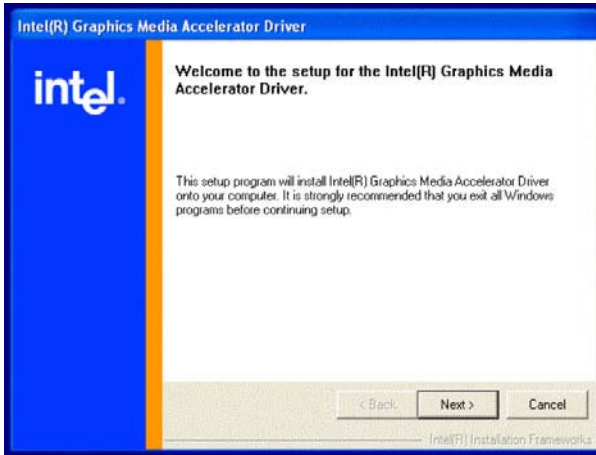

2. You will see a welcome window. Please click “Yes” to continue the installation.

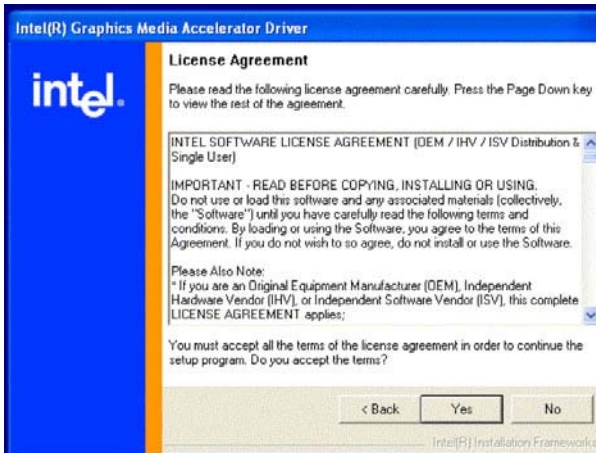

3. Click “Finish” to complete the installation and restart the computer now or later.



6

Video capture installation

Chapter 6 Video capture installation

6.1 Driver installation of video capture chip

Step 1: Pop-up the “System Properties” window, choose the “Hardware” page, and press the “Device Manager” bottom.

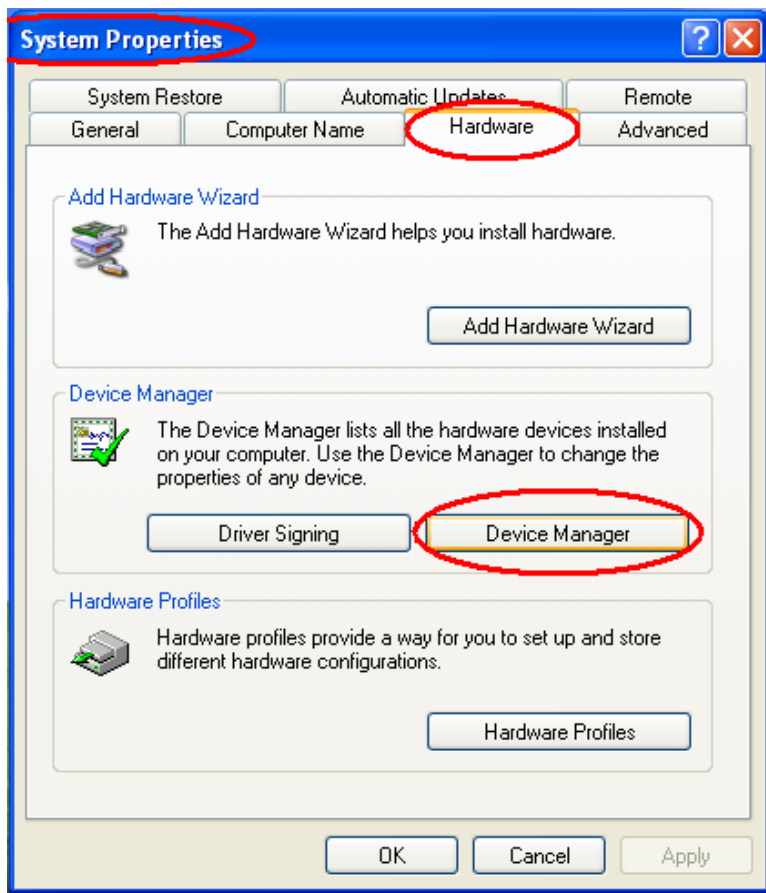

Step 2: Click the PC icon and press the left bottom of the mouse. Press the “Scan for hardware changes”.

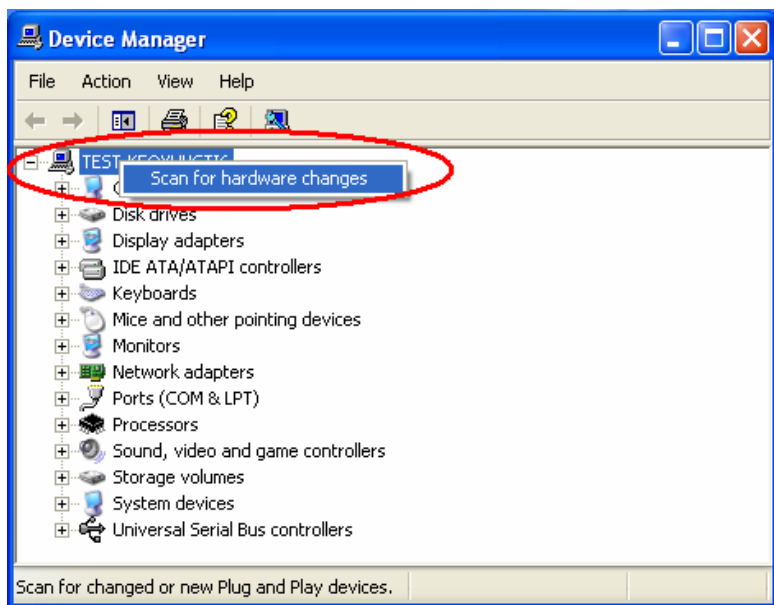

Step 3: The system will show the un-known devices like below window.

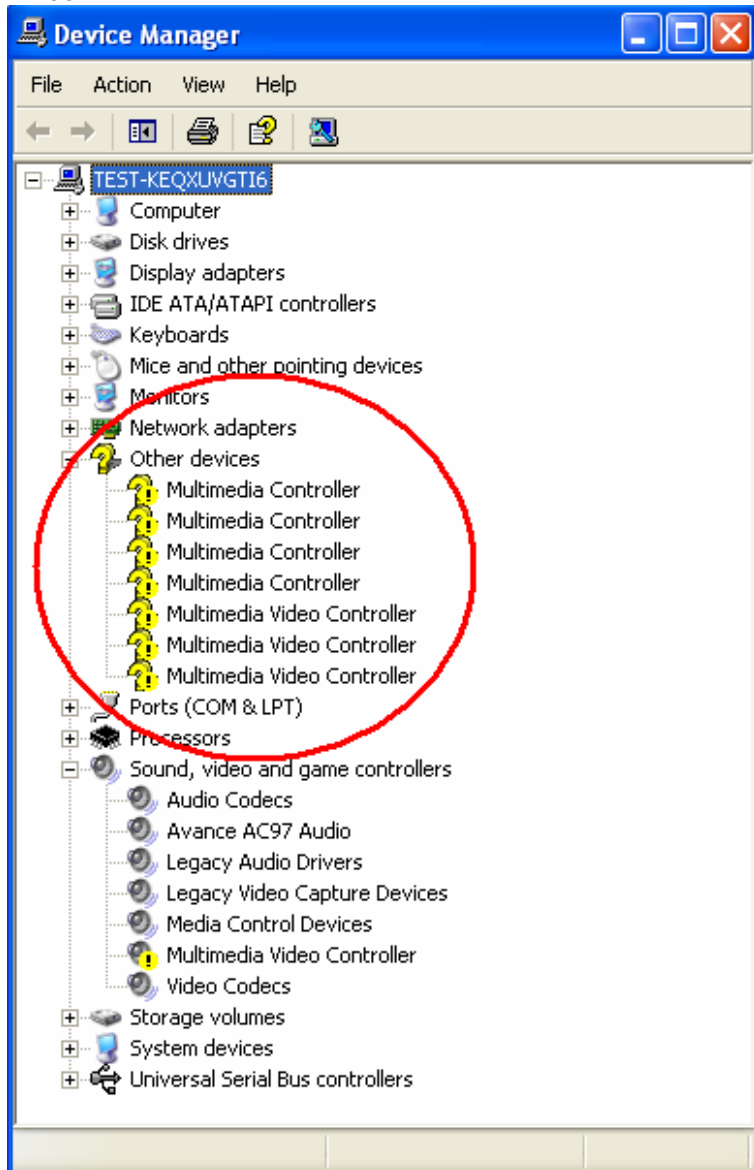

Step 4: Click the below icon to specify the driver location.

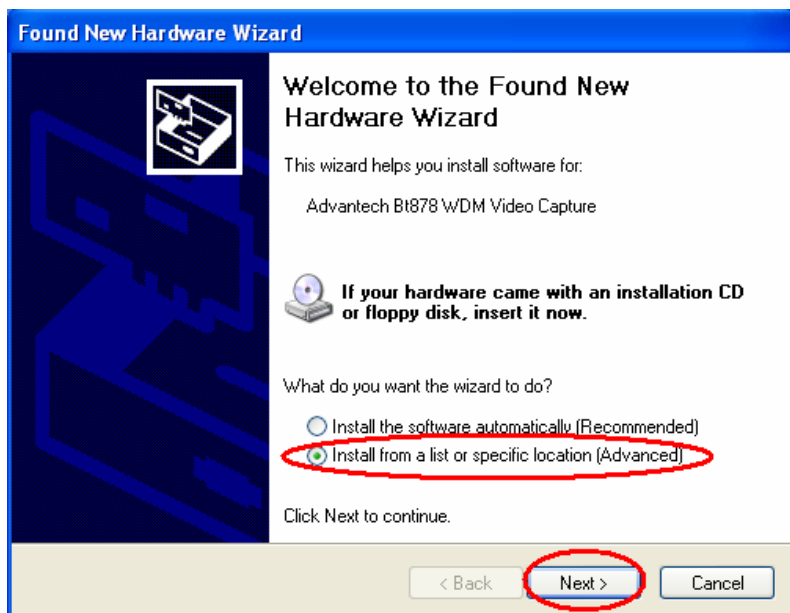

Step 5: Specify the driver under the DVMB-554E_CD\01_DVMB-554E_Driver\05_BT878 Driver

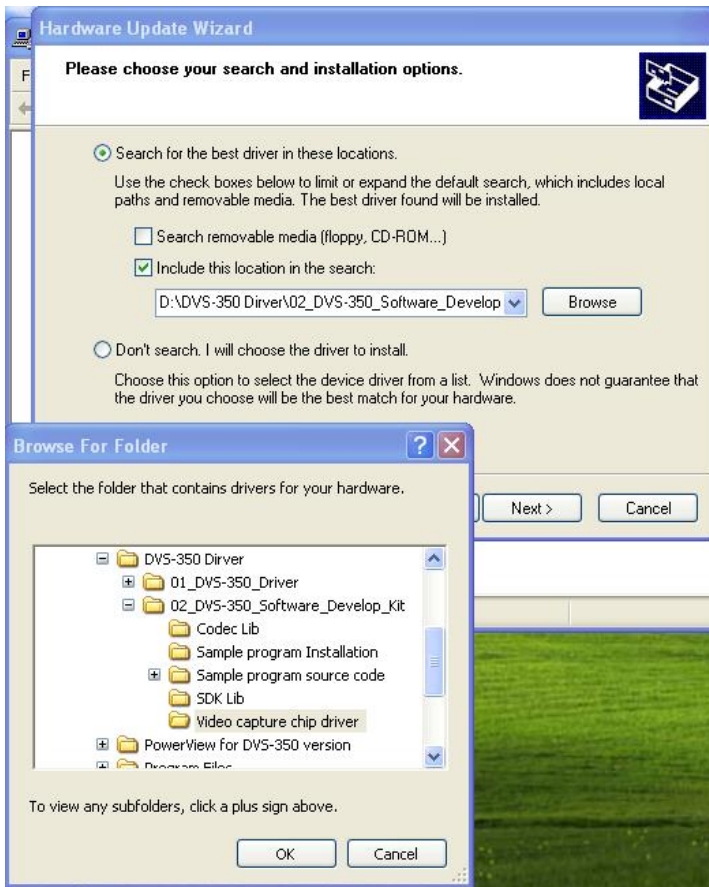

Step 6: Push the “Next” button to process the installation.

Step 7: Continuing the installation.

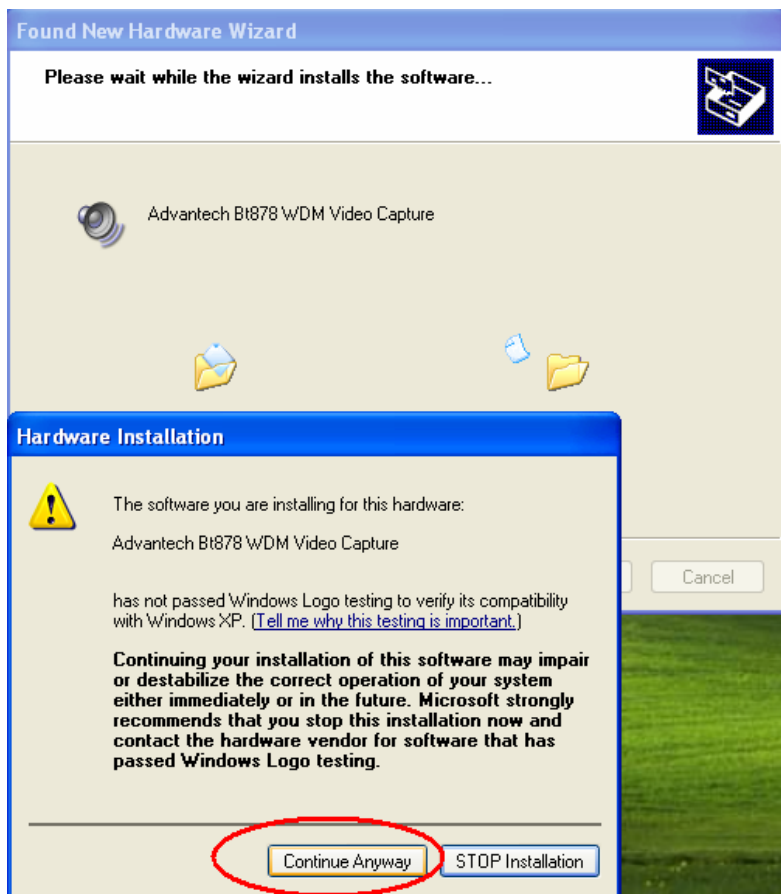

Step 8: Press the “Finish” button to finish the first circle installation. Then repeat the installation step 1~8 until all the un-known devices are all installed.

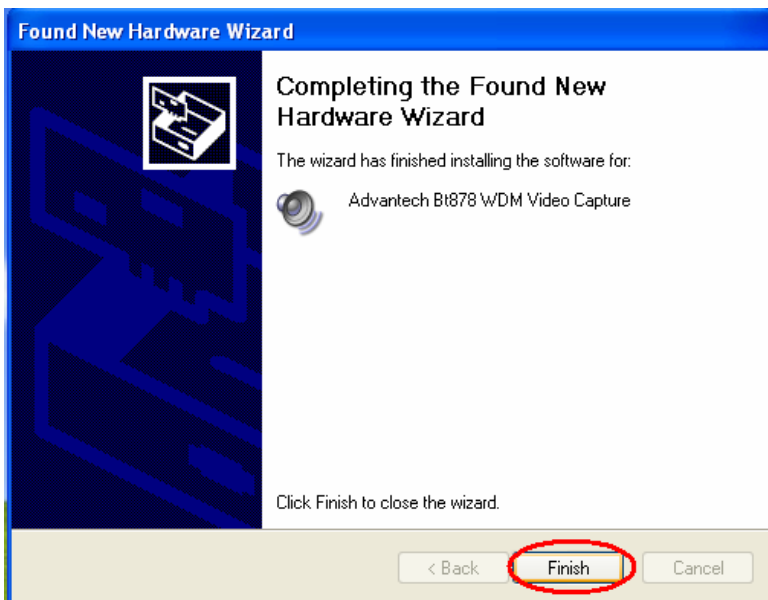

Step 9: From below window, we know there are 8 new items are installed.

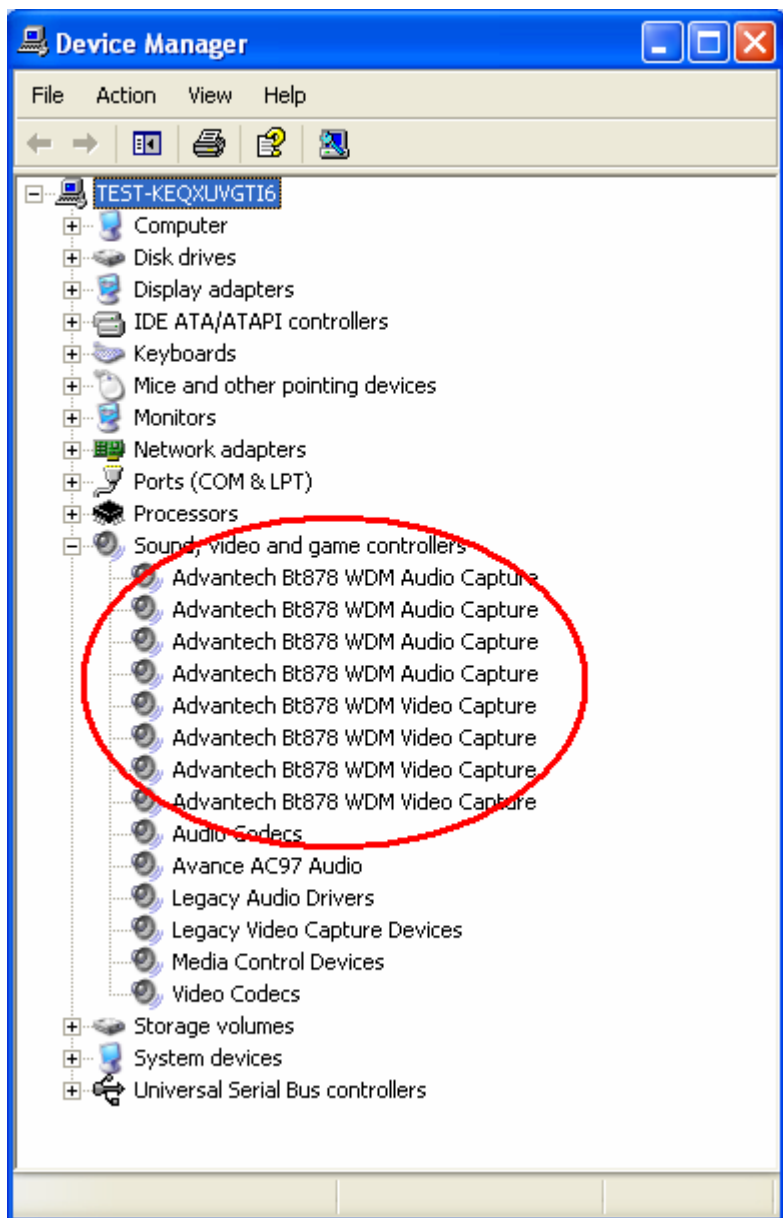

6.2 Installation of DVMB-554E Demo Program

Step 1: Install the DVMB-554E demo program. The executive file is in the path: DVMB-554E_CD\02_DVMB-554E_Software_Develop_Kit \Demo Program

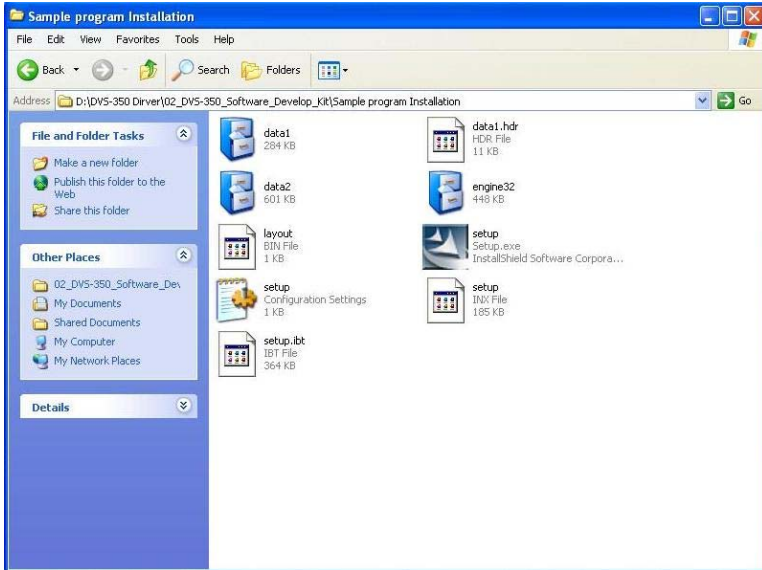

Step 2: Press the “Next” button to begin the installation.

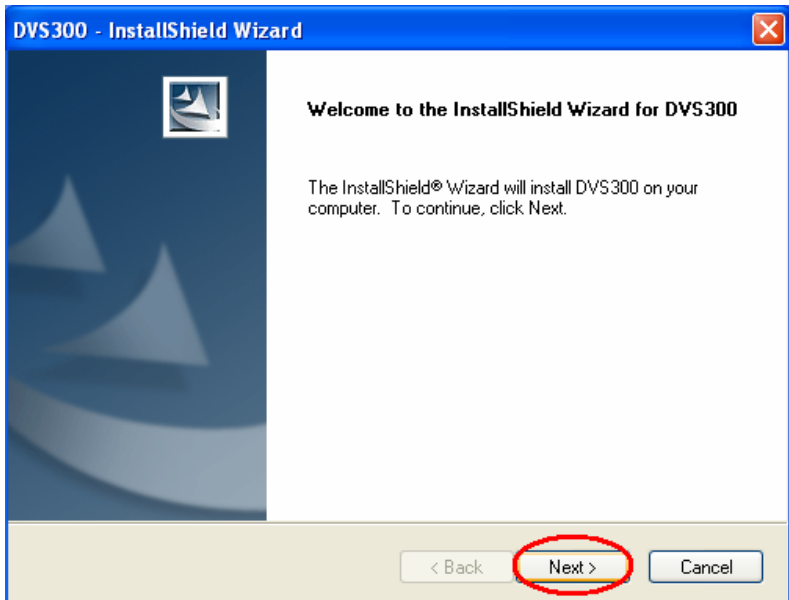

Step 3: Accept the license agreement and continue the installation.



Step 4: Key in your name and company name. Then press the “Next” button to continue.

DVS300 - InstallShield Wizard

Customer Information
Please enter your information.

Please enter your name and the name of the company for which you work.

User Name:
test

Company Name:
test

InstallShield

< Back **Next >** Cancel

Step 5: Choose the setup type you want and next.

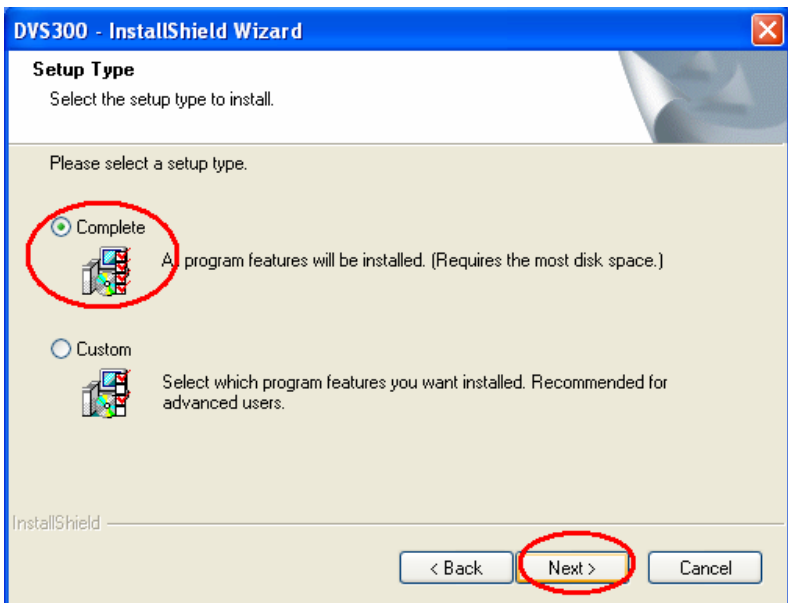

Step 6: Beginning the installation.

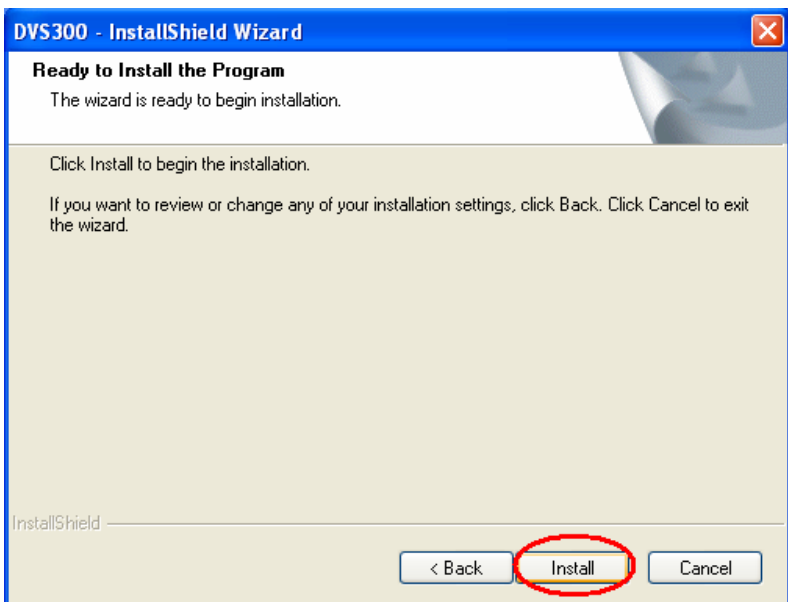

Step 7: Finished the installation of DVS-350 demo program.

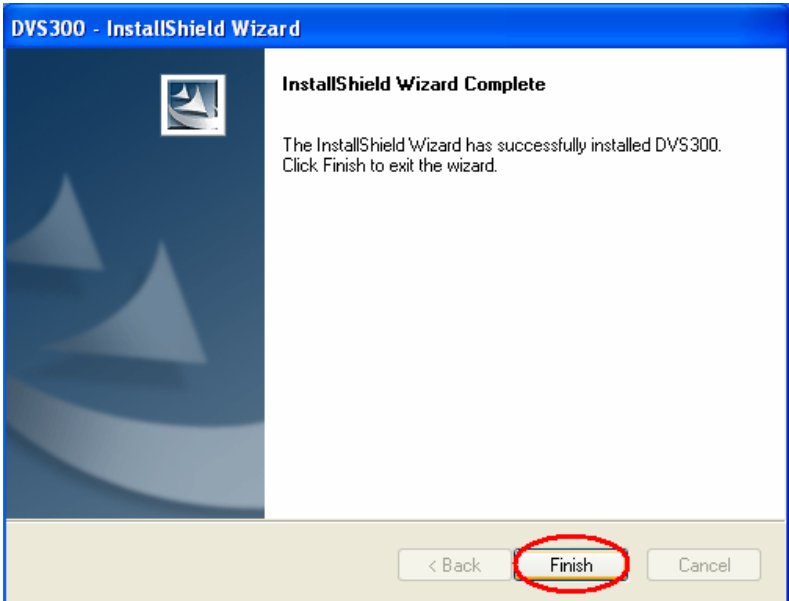

Step 8: There will be a DVMB554.exe icon on the desktop. Execute the demo program.

6.3 Demo Program Functionality

Below is the demo program window. The left side panels are the preview windows of video inputs. The right side panels are the function parameter settings.

6.3.1 Device

Each device is representative of one Conexant Fusion 878A video capture chip. User can set different parameters to different 878A chip.

Device	
Device	Device_0
Switch Channels	Device_0
Resolution	Device_1
Frame Rate	Device_2
Video Mux	Device_3
Video Standard	30
	0
	NTSC
	4
Start	Snap Buffer
Sensor Ctrl	Micro Ctrl
GPIO Ctrl	

Encoder	
Frame Rate	30
Key Interval	100
Quant	4
	<input checked="" type="checkbox"/> Save
	Encode
	Playback
Exit	

6.3.2 Switch Channels

Set the “Switch Channels” to decide how many input for each 878A video chip. Each 878A chip can switch to 4 channel video inputs to share 30/25 frame per second. For more information, please refer to DVMB554SDK_Manual

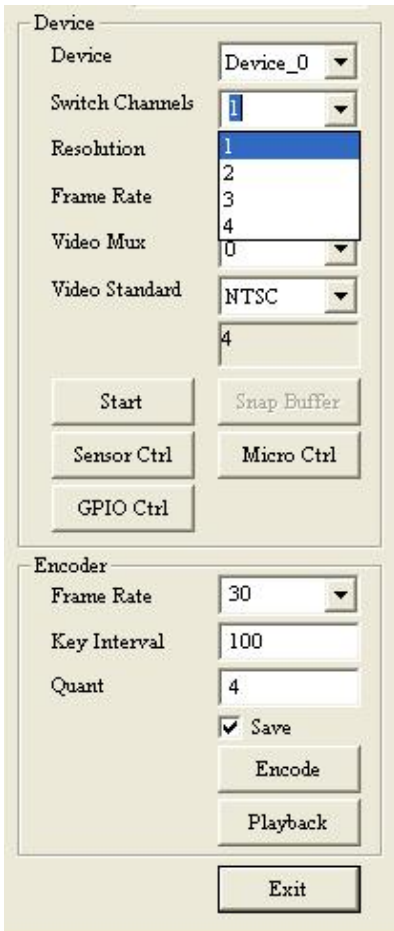

6.3.3 Resolution

Set the video capturing resolution. Please refer to DVMB554SDK_Manual

Notice: For the resolution of VGA or D1, the capture video will have the interlace effect on the video image. In other words, there will be lines in the capture image especially when the targeted image is moving. To eliminate this effect, user might need to set the resolution down to 640x240 and use specific algorithms to compensate the image interlace between the scanning even field image and odd field image. For CIF/320x240 resolution, there will be no interlace effect.

Device	
Device	Device_0
Switch Channels	1
Resolution	QVGA
Frame Rate	FULL PAL D1
Video Mux	VGA QVGA SUBQVGA
Video Standard	4
<input type="button" value="Start"/> <input type="button" value="Snap Buffer"/>	
<input type="button" value="Sensor Ctrl"/> <input type="button" value="Micro Ctrl"/>	
<input type="button" value="GPIO Ctrl"/>	
Encoder	
Frame Rate	30
Key Interval	100
Quant	4
<input checked="" type="checkbox"/> Save	
<input type="button" value="Encode"/>	
<input type="button" value="Playback"/>	
<input type="button" value="Exit"/>	

6.3.4 Frame Rate

Set the frame rate for video capturing for specific channel. Please refer to DVMB554SDK_Manual

Device	
Device	Device_0
Switch Channels	1
Resolution	QVGA
Frame Rate	30
Video Mux	26
Video Standard	27
	28
	29
	30
<input type="button" value="Start"/> <input type="button" value="Snap Buffer"/>	
<input type="button" value="Sensor Ctrl"/> <input type="button" value="Micro Ctrl"/>	
<input type="button" value="GPIO Ctrl"/>	
Encoder	
Frame Rate	30
Key Interval	100
Quant	4
	<input checked="" type="checkbox"/> Save
<input type="button" value="Encode"/>	
<input type="button" value="Playback"/>	
<input type="button" value="Exit"/>	

6.3.5 Video Mux

Set the "Video Mux" to specify the video input channel for setting parameter. Please refer to DVMB554SDK_Manual

Device	
Device	Device_0
Switch Channels	1
Resolution	QVGA
Frame Rate	30
Video Mux	0
Video Standard	0
	1
	2
	3
Start	Snap Buffer
Sensor Ctrl	Micro Ctrl
GPIO Ctrl	

Encoder	
Frame Rate	30
Key Interval	100
Quant	4
	<input checked="" type="checkbox"/> Save
	Encode
	Playback
	Exit

6.3.6 Video Standard

Set the video standard of your cameras. Please refer to DVMB554SDK_Manual.

Device

Device: Device_0

Switch Channels: 1

Resolution: QVGA

Frame Rate: 30

Video Mux: 0

Video Standard: NTSC

Encoder

Frame Rate: 30

Key Interval: 100

Quant: 4

Save

6.3.7 Snap Buffer

Press the “Snap Buffer” to get the image data of specific channel video input. The snap image will be show on the up panel.



Device	Device_2 ▾
Switch Channels	3 ▾
Resolution	QVGA ▾
Frame Rate	30.0 ▾
Video Mux	2 ▾
Video Standard	NTSC ▾
	4
	Stop
	Snap Buffer
	Sensor Ctrl
	Micro Ctrl
	GPIO Ctrl
	Exit

6.3.8 Sensor Control

To set the brightness, contrast, hue and saturation of specific channel. Please refer to DVMB554SDK_Manual

6.3.9 Micro Control

Specify or get the word address(0~127).with a value. Please refer to DVMB554SDK_Manual



6.3.10 GPIO control

To get a specified DI value or to set a specified DO value. Please refer to DVMB554SDK_Manual

